

## SA Combined Suction/Booster

Hydrant Boosters are designed in accordance with the requirements of AS2419.1-2005.

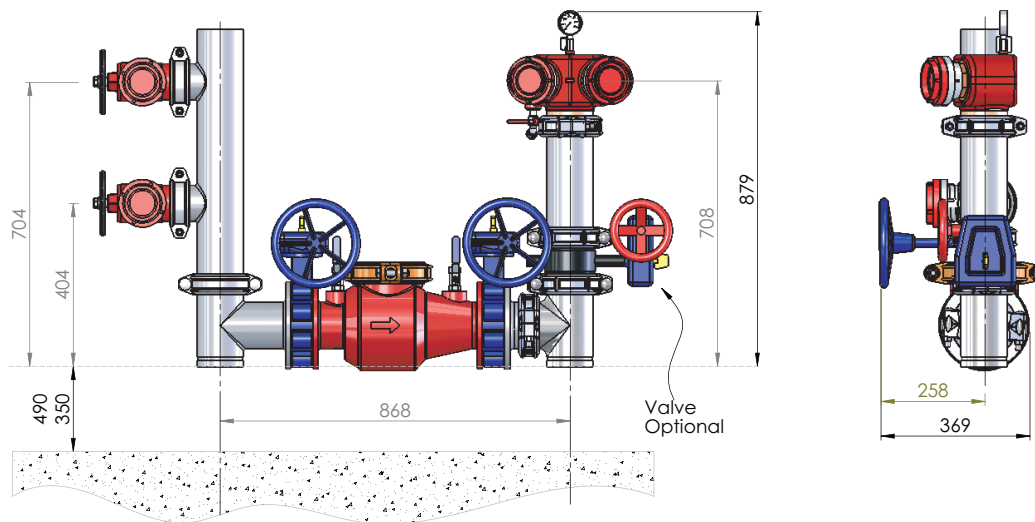

### 100NB Assembly

Part No.	Price \$
FFS-100MMCSB-A	4505.44

Note: Supplied unassembled  
Dimensions based on using Short Series Fittings

Price Group: FE  
FP02

K

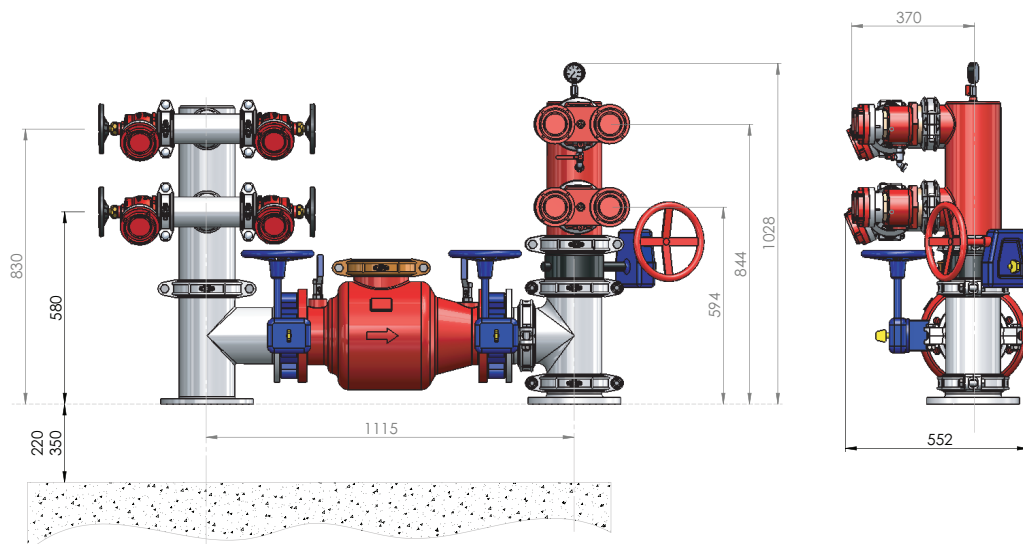

### 150NB Assembly

Part No.	Price \$
FFS-150MMCSB-A	8328.15

Note: Supplied unassembled  
Dimensions based on using Short Series Fittings  
200, 250 and 300mm suction/booster units also available - price on application. Supplied in compliance with AS2419.1

Price Group: FE  
FP02