

## NSW Combined Suction/Booster

Hydrant Boosters are designed in accordance with the requirements of AS2419.1-2005.

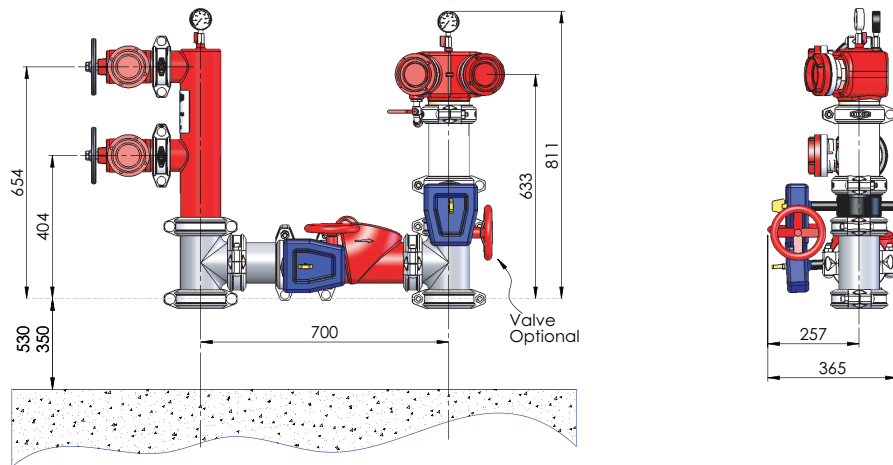

All Suction & Landing valves come fitted with Aluminium Forged alloy DIN Storz couplings as standard.

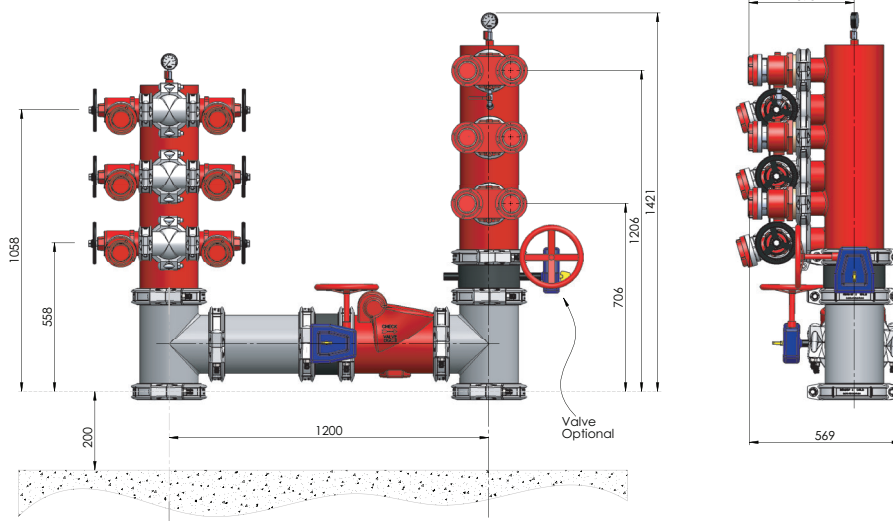
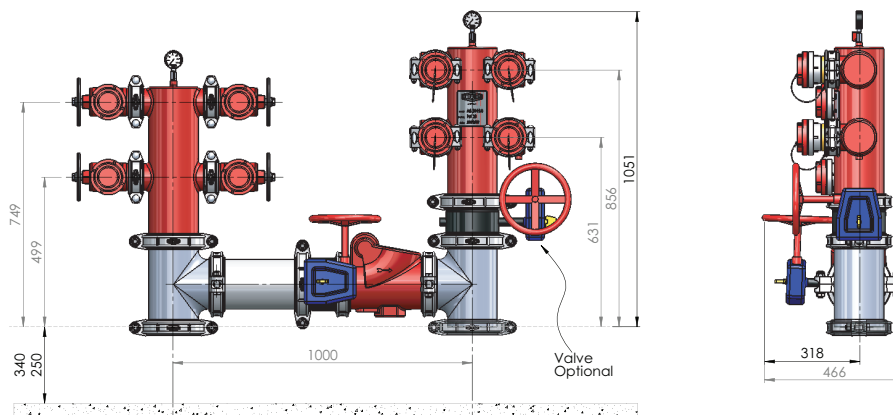

Part No.	Size NB	Description	Price \$
FFS-100MMCSB-S	100	2 Point Suction / Booster Assembly	4448.97
FFS-150MMCSB-S	150	4 Point Suction / Booster Assembly	9980.35
FFS-200MMCSB-S	200	6 Point Suction / Booster Assembly	11758.21

Note: Dimensions are based on using Short Series Fittings

Price Group: FE

FP02



1300 134 651  
dixonvalve.com.au

All prices exclude GST.  
ADPL718

