



# Hygienic Fittings

Product Brochure

1300 134 651 | [dixonvalve.com.au](http://dixonvalve.com.au)

## BSM Union (RJT) Fittings

### Application

- Australia commonly employs unions featuring a captive seal design for a seamless, crevice-free internal bore. These hygienic unions play a crucial role in the food and beverage industry, facilitating the connection of tubes, valves, pumps, tanks, or hoses. Distinguished by a distinct liner and a genuine O-ring in contrast to the New Zealand version, they offer versatility with various elastomer O-rings tailored to specific applications. Users can choose between two types of nuts: slotted and hexed.

### RJT Welding Male

#### Standard

- RJT (BSM) AS1528.2 - 2001 screwed couplings

#### Material

- 316 stainless steel

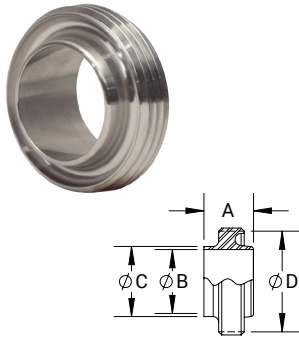

Size		Part Numbers	A (mm)	B (mm)	C (mm)	D (mm)
mm	inch					
25.4	1	15A-R100RJT	27.0	22.1	25.4	45.7 x 8T
38.1	1½	15A-R150RJT	27.0	34.8	38.1	58.4 x 8T
50.8	2	15A-R200RJT	27.0	47.5	50.8	72.7 x 6T
63.5	2½	15A-R250RJT	27.0	60.2	63.5	85.4 x 6T
76.2	3	15A-R300RJT	27.0	72.9	76.2	98.1 x 6T
101.6	4	15A-R400RJT	27.0	97.4	101.85	123.5 x 6T

Product Group: AV02

### Welding Male CIP Flat Face

#### Standard

- Flat face couplings AS1528.2 - 2001 screwed couplings

#### Material

- 316 stainless steel

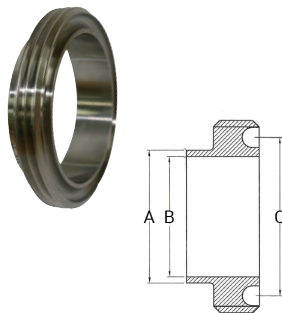

Size		Part Numbers	A (mm)	B (mm)	C (mm)
mm	inch				
25.4	1	15A-R100RJT-CIP	22.0	22.2	25.4
38.1	1½	15A-R150RJT-CIP	22.0	34.9	38.1
50.8	2	15A-R200RJT-CIP	22.0	47.6	50.8
63.5	2½	15A-R250RJT-CIP	22.0	60.3	63.5
76.2	3	15A-R300RJT-CIP	22.0	73.0	76.2
101.6	4	15A-R400RJT-CIP	22.0	98.4	101.6

Product Group: AV02

### RJT Welding Liner

#### Standard

- RJT (BSM) AS1528.2 - 2001 screwed couplings

#### Material

- 316 stainless steel

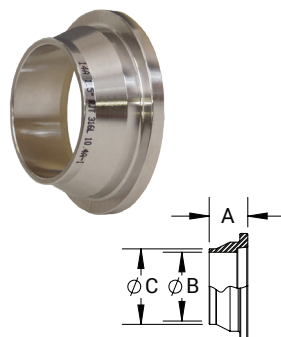

Size		Part Numbers	A (mm)	B (mm)	C (mm)
mm	inch				
25.4	1	14A-R100RJT	19.5	22.1	25.4
38.1	1½	14A-R150RJT	19.5	34.8	38.1
50.8	2	14A-R200RJT	19.5	47.5	50.8
63.5	2½	14A-R250RJT	19.5	60.2	63.5
76.2	3	14A-R300RJT	19.5	72.9	76.2
101.6	4	14A-R400RJT	19.5	97.4	101.85

Product Group: AV02

### Welding Liner CIP Flat Face

#### Standard

- Flat face couplings AS1528.2 - 2001 screwed couplings

#### Material

- 316 stainless steel

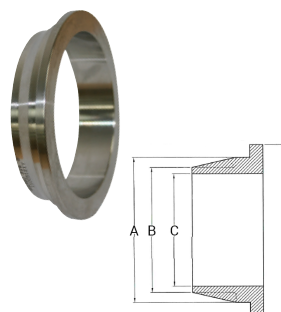

Size		Part Numbers	A (mm)	B (mm)	C (mm)	D (mm)
mm	inch					
25.4	1	14A-R100RJT-CIP	32.6	25.4	22.2	41.3
38.1	1½	14A-R150RJT-CIP	45.3	38.1	34.9	54.0
50.8	2	14A-R200RJT-CIP	58.0	50.8	47.6	66.7
63.5	2½	14A-R250RJT-CIP	70.7	63.5	60.3	79.4
76.2	3	14A-R300RJT-CIP	83.4	76.2	73.0	92.1
101.6	4	14A-R400RJT-CIP	108.8	101.6	98.4	117.5

Product Group: AV02

BSM Union (RJT) Fittings

RJT Round Slotted Nut

Standard

- RJT (BSM) AS1528.2 - 2001 screwed couplings

Material

- 304 stainless steel

Size		Part Numbers	A (mm)	B (mm)	C (mm)
mm	inch				
25.4	1	13R-G100RJT	58.5	49.3	33.3
38.1	1½	13R-G150RJT	74.0	63.5	46.0
50.8	2	13R-G200RJT	85.5	77.5	58.7
63.5	2½	13R-G250RJT	98.5	90.5	71.4
76.2	3	13R-G300RJT	111.6	102.0	84.1
101.6	4	13R-G400RJT	138.0	129.0	109.5

Product Group: AV02

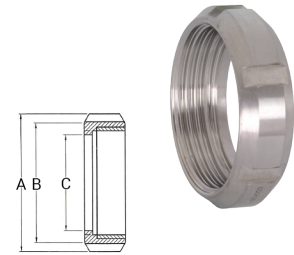

RJT Hex Nut

Standard

- RJT (BSM) AS1528.2 - 2001 screwed couplings

Material

- 304 stainless steel

Size		Part Numbers	A (mm)	B (mm)
mm	inch			
25.4	1	13H-G100RJT	22.2	42.3 x 8TPI WHIT
38.1	1½	13H-G150RJT	22.2	55.0 x 8TPI WHIT
50.8	2	13H-G200RJT	22.2	67.9 x 6TPI WHIT
63.5	2½	13H-G250RJT	22.2	80.6 x 6TPI WHIT
76.2	3	13H-G300RJT	22.2	93.3 x 6TPI WHIT
101.6	4	13H-G400RJT	22.2	118.7 x 6TPI WHIT

Product Group: AV02

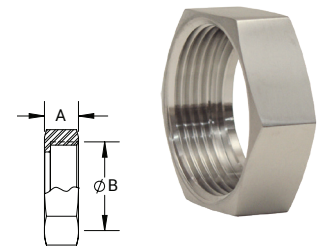

RJT Round Blank Cap

Standard

- RJT (BSM) AS1528.2 - 2001 screwed couplings

Material

- 304 stainless steel

Size		Part Numbers	A (mm)	B (mm)
mm	inch			
25.4	1	13RBN-G100RJT	32.5	41.3
38.1	1½	13RBN-G150RJT	45.2	54.0
50.8	2	13RBN-G200RJT	57.9	66.7
63.5	2½	13RBN-G250RJT	70.6	79.4
76.2	3	13RBN-G300RJT	83.3	92.1
101.6	4	13RBN-G400RJT	108.7	117.5

Product Group: AV02

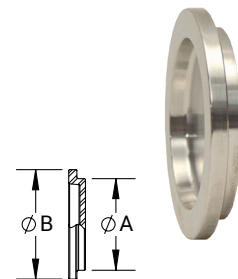

RJT Hex Blank

Material

- 316 stainless steel

Size		Part Numbers
mm	inch	
25.4	1	13HBN-G100RJT
38.1	1½	13HBN-G150RJT
50.8	2	13HBN-G200RJT
63.5	2½	13HBN-G250RJT
76.2	3	13HBN-G300RJT
101.6	4	13HBN-G400RJT

Product Group: AV02



## RJT Hex Spanner

### Standard

- Single-sided - 25H

### Material

- Aluminium

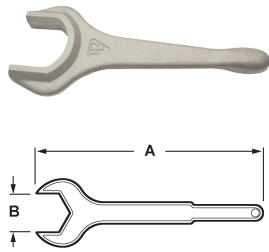

Size		Part Numbers	A (mm)	B (mm)
mm	inch			
25.4	1	RJT-100SP	254.00	50.80
38.1	1½	RJT-150SP	292.10	65.02
50.8	2	RJT-200SP	304.80	79.25
63.5	2½	RJT-300SP	342.80	91.95
76.2	3	RJT-400SP	368.30	104.65
101.6	4	RJT-500SP	444.50	130.05

Product Group: AV02

## BSM (RJT) O-Rings

### Standard

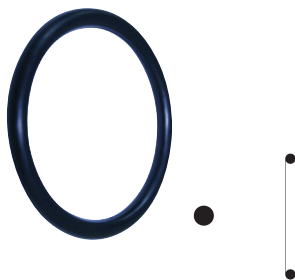

Size		Part Numbers			ID (mm)	Width (mm)
mm	inch	Buna - NBR	EPDM	FKM		
25.4	1	40MP-U100RJT	40MP-E100RJT	40MP-SFY100RJT	26.92	6.35
38.1	1½	40MP-U150RJT	40MP-E150RJT	40MP-SFY150RJT	39.62	6.35
50.8	2	40MP-U200RJT	40MP-E200RJT	40MP-SFY200RJT	52.32	6.35
63.5	2½	40MP-U250RJT	40MP-E250RJT	40MP-SFY250RJT	65.08	6.35
76.2	3	40MP-U300RJT	40MP-E300RJT	40MP-SFY300RJT	77.72	6.35
101.6	4	40MP-U400RJT	40MP-E400RJT	40MP-SFY400RJT	103.12	6.35

Product Group: AV02

### CIP

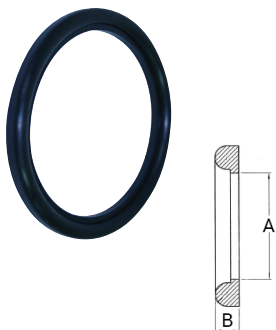

Size		Part Numbers		A (mm)	B (mm)
mm	inch	Buna - NBR	EPDM		
25.4	1	40MP-U100RJT-CIP	40MP-E100RJT-CIP	22.2	7.0
38.1	1½	40MP-U150RJT-CIP	40MP-E150RJT-CIP	34.9	7.0
50.8	2	40MP-U200RJT-CIP	40MP-E200RJT-CIP	47.6	7.0
63.5	2½	40MP-U250RJT-CIP	40MP-E250RJT-CIP	60.3	7.0
76.2	3	40MP-U300RJT-CIP	40MP-E300RJT-CIP	72.9	7.0
101.6	4	40MP-U400RJT-CIP	40MP-E400RJT-CIP	98.4	7.0
152.4	6	-	40MP-E600RJT-CIP	149.2	7.0

Product Group: AV02

## Double Rolled Hose Tail

### Material

- 304 stainless steel



Size		Part Numbers
mm	inch	
25.4	1	HTWE-100
38.1	1½	HTWE-150
50.8	2	HTWE-200
63.5	2½	HTWE-250
76.2	3	HTWE-300
101.6	4	HTWE-400

Product Group: AV11

## NZ RJT Fittings

### Application

- Used in the food and beverage industry, hygienic unions are used to connect tubes, valves, pumps, tanks, or hoses. A captive seal design is used to provide a smooth, crevice-free internal bore. The NZ RJT uses a slightly different liner and o-ring/gasket, but the nuts and males can be interchanged with the Australian and British versions. The nuts are available either hex or round (slotted). Different elastomer o-rings are available depending on the application.

### RJT Welding Liner

#### Material

- 316 stainless steel AS1528.2

Size		Part Numbers	A (mm)	B (mm)	C (mm)
mm	inch				
25.4	1	14A-R100RJT-NZ	22.2	25.6	25.4
38.1	1½	14A-R150RJT-NZ	34.8	38.1	38.1
50.8	2	14A-R200RJT-NZ	47.5	50.8	50.8
63.5	2½	14A-R250RJT-NZ	60.2	63.5	63.5
76.2	3	14A-R300RJT-NZ	72.9	76.2	76.2
101.6	4	14A-R400RJT-NZ	97.6	101.8	101.6
152.4	6	14A-R600RJT-NZ	147.7	152.4	152.4

Product Group: AV02

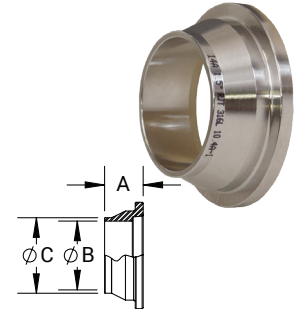

### RJT Round Slotted Nut

#### Material

- 304 stainless steel

Size		Part Numbers	A (mm)	B (mm)
mm	inch			
25.4	1	13R-G100RJT	22.2	58.5
38.1	1½	13R-G150RJT	22.2	74
50.8	2	13R-G200RJT	22.2	85.5
63.5	2½	13R-G250RJT	22.2	98.5
76.2	3	13R-G300RJT	22.2	111.6
101.6	4	13R-G400RJT	22.2	138

Product Group: AV02

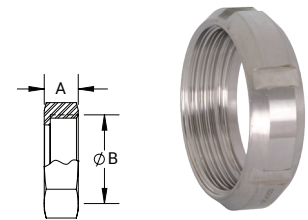

### RJT Hex Nut

#### Material

- 304 stainless steel

Size		Part Numbers	A (mm)	B (mm)
mm	inch			
25.4	1	13H-G100RJT	22.2	42.3 x 8TPI WHIT
38.1	1½	13H-G150RJT	22.2	55.0 x 8TPI WHIT
50.8	2	13H-G200RJT	22.2	67.9 x 6TPI WHIT
63.5	2½	13H-G250RJT	22.2	80.6 x 6TPI WHIT
76.2	3	13H-G300RJT	22.2	93.3 x 6TPI WHIT
101.6	4	13H-G400RJT	22.2	118.7 x 6TPI WHIT

Product Group: AV02

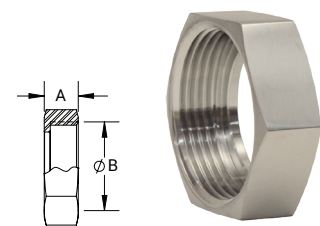

## NZ RJT O-Rings

Size		Part Numbers		ID (mm)	Width (mm)
mm	inch	FKM	EPDM		
25.4	1	40MP-SFY100RJT-NZ	40MP-E100RJT-NZ-NZ	33.3	12.5
38.1	1½	40MP-SFY150RJT-NZ	40MP-E150RJT-NZ-NZ	46	12.5
50.8	2	40MP-SFY200RJT-NZ	40MP-E200RJT-NZ-NZ	58.7	12.5
63.5	2½	40MP-SFY250RJT-NZ	40MP-E250RJT-NZ-NZ	71.4	12.5
76.2	3	40MP-SFY300RJT-NZ	40MP-E300RJT-NZ-NZ	84.1	12.5
101.6	4	40MP-SFY400RJT-NZ	40MP-E400RJT-NZ-NZ	109.5	12.5
152.4	6	40MP-SFY600RJT-NZ	40MP-E600RJT-NZ-NZ	160.3	13.5

Product Group: AV02

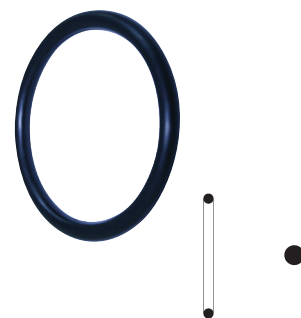

# Hygienic Fittings

## DIN Union Fittings

### Application

- DIN Unions (German Institute for Standardisation) are used in conjunction with German and other European equipment. They are manufactured in accordance with DIN 11851 (EN10357). Consisting of a round slotted nut, weld liner, weld male and seal. A captive seal design is used to provide a smooth, crevice-free internal bore. Different elastomer o-rings are available depending on the application. Can be supplied in either imperial or metric DIN.

### DIN Weld Male

#### Material

- 316 stainless steel

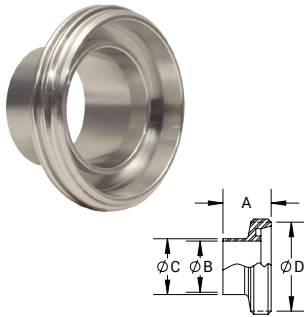

Size		Part Numbers	A (mm)	B (mm)	C (mm)	D (mm)
mm	inch					
12.7	½	15A-R50DIN	21	12.7	18	Rd 34 x 1/6"
25.4	1	15A-R100DIN	29	25.4	28	Rd 52 x 1/6"
38.1	1½	15A-R150DIN	33	38.1	40	Rd 65 x 1/6"
50.8	2	15A-R200DIN	35	50.8	52	Rd 78 x 1/6"
63.5	2½	15A-R250DIN	40	63.5	70	Rd 95 x 1/6"
76.2	3	15A-R300DIN	45	76.2	85	Rd 110 x 1/4"
101.6	4	15A-R400DIN	54	101.6	104	Rd 130 x 1/4"

Product Group: AV10

### DIN Weld Liner

#### Material

- 316 stainless steel

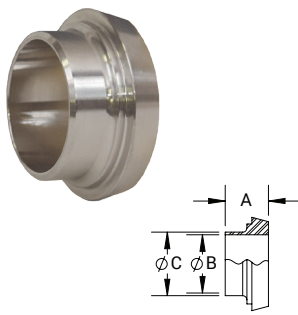

Size		Part Numbers	A (mm)	B (mm)	C (mm)
mm	inch				
12.7	½	14A-R15DIN	17	12.7	12
25.4	1	14A-R100DIN	22	25.4	28
38.1	1½	14A-R150DIN	26	38.1	40
50.8	2	14A-R200DIN	28	50.8	52
63.5	2½	14A-R250DIN	32	63.5	70
76.2	3	14A-R300DIN	37	76.2	85
101.6	4	14A-R400DIN	44	101.6	104

Product Group: AV10

### DIN Round Slotted Nut

#### Standard

- DN 11851/11887 couplings & gaskets

#### Material

- 304 stainless steel

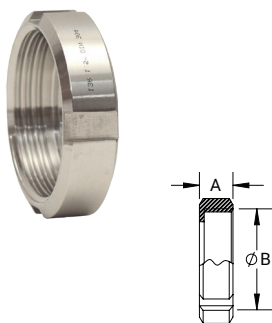

Size		Part Numbers	A (mm)	B (mm)
mm	inch			
12.7	½	13R-G50DIN	18	Rd 34 x 1/6"
25.4	1	13R-G100DIN	21	Rd 52 x 1/6"
38.1	1½	13R-G150DIN	21	Rd 65 x 1/6"
50.8	2	13R-G200DIN	22	Rd 78 x 1/6"
63.5	2½	13R-G250DIN	25	Rd 95 x 1/6"
76.2	3	13R-G300DIN	29	Rd 110 x 1/4"
101.6	4	13R-G400DIN	31	Rd 130 x 1/4"

Product Group: AV10

### DIN Blank

#### Material

- 316 stainless steel

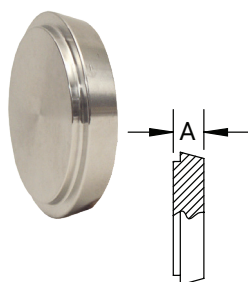

Size		Part Numbers	A (mm)
mm	inch		
25.4	1	16AMP-R100DIN	13
38.1	1½	16AMP-R150DIN	13
50.8	2	16AMP-R200DIN	14
63.5	2½	16AMP-R250DIN	16
76.2	3	16AMP-R300DIN	16
101.6	4	16AMP-R400DIN	20

Product Group: AV10

## DIN 11851/11887 Gaskets

Size		Part Numbers	ID (mm)	OD (mm)
mm	inch			
		<b>EPDM</b>		
25.4	1	40MP-E100DIN	26.92	39.88
38.1	1½	40MP-E150DIN	39.62	52.07
50.8	2	40MP-E200DIN	52.32	64.01
63.5	2½	40MP-E250DIN	65.08	81.03
76.2	3	40MP-E300DIN	77.72	95.00
101.6	4	40MP-E400DIN	103.12	114.05

Product Group: AV10

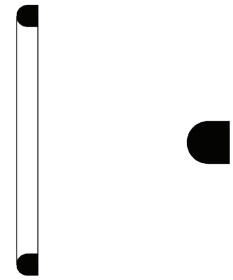

## DIN Spanner

### Standard

- Single-sided - 25H

### Material

- Nickel plated steel

Size		Part Numbers	A (mm)
mm	inch		
25.4 - 38.1	1 - 1½	DIN-SMS-60/90SP	247.7
50.8 - 101.6	2 - 4	DIN-SMS-90/155SP	330.2

Product Group: AV10

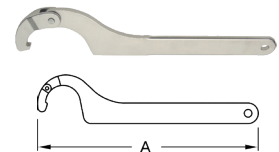

## BSP Lockable Sample Tap

### Material

- 316 stainless steel

Size		Part Numbers	
mm	inch	Sample Tap	Service Kit
12.7	½	BSVWBS-R50	BSVWBS-RK50

Product Group: AV11

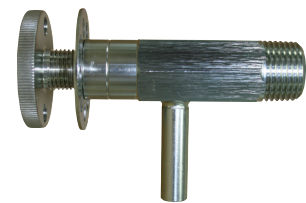

# Food & Beverage Processing

In addition to our **broad range** of hygienic fittings, our value-added services enable us to incorporate food-quality hose assemblies seamlessly into our comprehensive range of hygienic fittings.





## Wine Fittings

### Application

- Introducing a new wine fitting design that prioritises hygiene and efficiency. This retrofit design seamlessly integrates with your existing fittings by aligning threads, eliminating the need for costly replacements. Featuring an O-ring for a reliable seal under pressure, it is securely retained and prevents loss without the use of a tool. The internals boasts a hygienic smooth edge design, and fittings from 1.5" to 4" require no extra machining due to a 1.6mm wall thickness. The redesigned tri-nut enhances practicality, making manoeuvring hose assemblies around your winery effortless.

### Wine Weld Male

#### Material

- 316 stainless steel



Size		Part Numbers
mm	inch	
25.4	1	15A-R150WM
38.1	1½	15A-R200WM
50.8	2	15A-R250WM
63.5	2½	15A-R300WM
76.2	3	15A-R400WM
101.6	4	15A-R400WM

Product Group: AV11

### Wine Weld Liner

#### Material

- 316 stainless steel

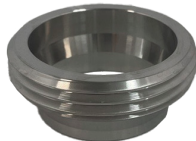

Size		Part Numbers
mm	inch	
25.4	1	14A-R150WL
38.1	1½	14A-R200WL
50.8	2	14A-R250WL
63.5	2½	14A-R300WL
76.2	3	14A-R400WL
101.6	4	14A-R400WL

Product Group: AV11

### Wine Weld Nut

#### Material

- Brass



Size		Part Numbers
mm	inch	
25.4	1	13W-B150WN
38.1	1½	13W-B200WN
50.8	2	13W-B250WN
63.5	2½	13W-B300WN
76.2	3	13W-B400WN
101.6	4	13W-B400WN

Product Group: AV11

### Wine O-ring

#### Material

- Silicone



Size		Part Numbers
mm	inch	
38.1	1½	40MP-S150R
50.8	2	40MP-S200R
63.5	2½	40MP-S250R
76.2	3	40MP-S300R
101.6	4	40MP-S400R

Product Group: AV11



## Clever Clamp™

### Application

- The Dixon™ Clever Clamp™ offers a new perspective on an age-old design. With its easy-to-use lever closure, it provides fast and consistent compression on both rubber and PTFE gasket connections every time. No torquing, no tools; just clap and go! Can be installed anywhere a traditional tri-clamp is used.

### Features

- Consistent compression of the gasket with every use:
  - No concern for damage to the gasket from overcompression or creating internal bacterial traps from over or under compression. ASME BPE capable
- Adjustable for both rubber and PTFE gasket styles
- Fast installation, no torquing tools required
- Threadless design eliminates the risk of damaged threads leading to improper tightening of wingnut
- Lockout-ready design, and aligned holes in the clamp body make cable locking fast and easy
- Self-locking lever and colour-coding options available

### Material

- 304 stainless steel

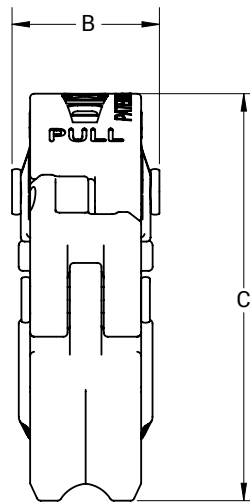
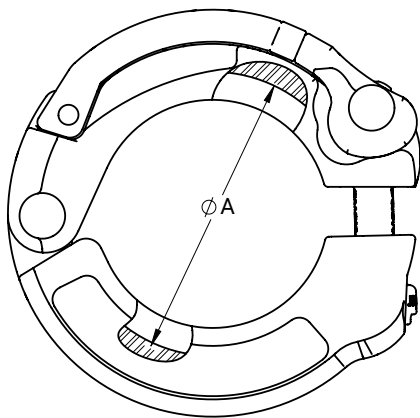

Scan here for the Clever Clamp™ video

Size		Part Numbers		A (inch)	B (inch)	C (inch)
mm	inch	Standard	Self-Locking Lever			
38.1	1½	13SCC-100150	13SCC-100150L	2.14	1.10	3.04
50.8	2	13SCC-200	13SCC-200L	2.65	1.10	3.53
76.2	3	13SCC-300	13SCC-300L	3.72	1.10	4.59
101.6	4	13SCC-400	13SCC-400L	4.82	1.10	5.62

Product Group: AV03



## Clever Clamp™ Add-On Features

### Applications

- Interchangeable coloured food-grade silicone ID bands for customisable process line identification.

### Food Grade ID Bands

Colour	Part Numbers
Red	13SCC-CB-R
Green	13SCC-CB-G
Blue	13SCC-CB-B
Yellow	13SCC-CB-Y

Product Group: AV03

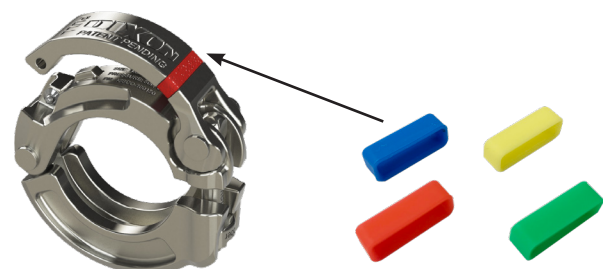

## Stainless Steel Sanitary Clamps

### Application

- Due to their hygienic design and simplicity of assembly and disassembly, stainless steel sanitary clamps are frequently used in the brewing and winemaking sectors as well as in the general food and beverage business. These clamps are often constructed from stainless steel, either 304 or 316, making them sturdy and corrosion-resistant. They are made to firmly join two pieces of piping or tubing, preventing leaks and product contamination throughout the transfer process. The clamps' smooth surface is crucial for upholding the hygienic standards necessary for the processing of food and beverages. This makes them simple to clean and sterilise, which is crucial in fields where cleanliness is of utmost importance.

### Single Pin Heavy Duty Clamps

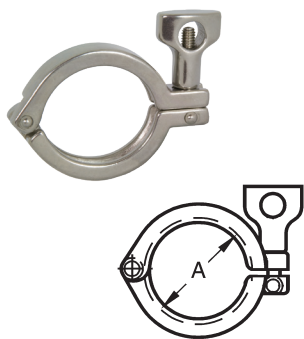

Size		Part Numbers	Service Pressure Rating @ 21 (PSI)	Dimension A (mm)
mm	inch			
12.7 - 19.05	½ - ¾	13MHHM50-75	1500	1.062
25.4 - 38.1	1 - 1½	13MHHM100150	500	2.122
50.8	2	13MHHM200	450	2.654
63.5	2½	13MHHM250	400	3.185
76.2	3	13MHHM300	350	3.717
101.6	4	13MHHM400	300	4.820
152.4	6	13MHHM600	150	6.625
203.2	8	13MHHM800	100	8.695

Product Group: AV03

### Bolted Clamps

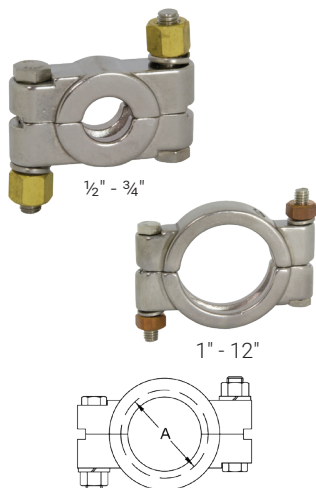

Size		Part Numbers	Service Pressure Rating @ 21°C (PSI)	Service Pressure Rating @ 121 (PSI)	Dimension A (mm)
mm	inch				
12.7 - 19.05	½ - ¾	13MHP75	1500	1200	1.062
25.4 - 38.1	1 - 1½	13MHP100-150	1500	1200	2.046
50.8	2	13MHP200	1000	800	2.578
63.5	2½	13MHP250	1000	800	3.110
76.2	3	13MHP300	1000	800	3.640
101.6	4	13MHP400	800	600	4.744
152.4	6	13MHP600	300	200	6.632
203.2	8	13MHP800	250	150	8.638
254	10	13MHP1000	200	125	10.740
304.8	12	13MHP1200	150	100	12.740

Product Group: AV03

### Stainless Steel Sanitary Clamp Solid End Caps

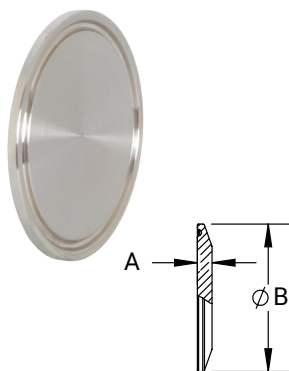

Size		Part Numbers		A (mm)	B (mm)
mm	inch	SS316	SS304		
12.7 - 19.05	½ - ¾	16AMP-R50-75	16AMP-G50-75	6.35	25.15
25.4 - 38.1	1 - 1½	16AMP-R100-150	16AMP-G100-150	6.35	50.29
50.8	2	16AMP-R200	16AMP-G200	6.35	64.00
63.5	2½	16AMP-R250	16AMP-G250	6.35	77.47
76.2	3	16AMP-R300	16AMP-G300	6.35	90.93
101.6	4	16AMP-R400	16AMP-G400	7.87	118.87
152.4	6	16AMP-R600	16AMP-G600	11.17	166.62
203.2	8	16AMP-R800	16AMP-G800	11.17	218.44
254	10	16AMP-R1000	16AMP-G1000	11.17	268.48
304.8	12	16AMP-R1200	16AMP-G1200	11.17	319.28

Product Group: AV03

Sanitary Clamp Short Welding Ferrules

Size		Part Numbers		A (mm)	B (mm)	C (mm)
mm	inch	SS316	SS304			
12.7	½	14WMP-R50	14WMP-G50	12.70	9.40	12.70
19.05	¾	14WMP-R75	14WMP-G75	12.70	15.75	19.05
25.4	1	14WMP-R100	14WMP-G100	12.70	22.10	25.40
38.1	1½	14WMP-R150	14WMP-G150	12.70	34.80	38.10
50.8	2	14WMP-R200	14WMP-G200	12.70	47.50	50.80
63.5	2½	14WMP-R250	14WMP-G250	12.70	60.20	63.50
76.2	3	14WMP-R300	14WMP-G300	12.70	72.90	76.20
101.6	4	14WMP-R400	14WMP-G400	15.75	97.28	101.6
152.4	6	14WMP-R600	14WMP-G600	19.05	146.81	152.4
203.2	8	14WMP-R800	14WMP-G800	22.35	197.61	203.2
254	10	14WMP-R1000	14WMP-G1000	22.35	247.90	254.0
304.8	12	14WMP-R1200	14WMP-G1200	22.35	298.70	304.8

Product Group: AV03

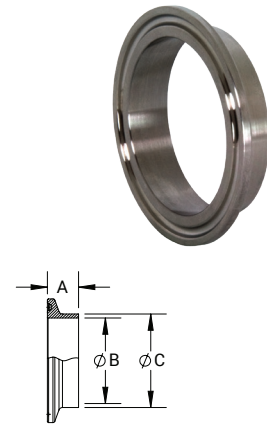

Sanitary Clamp Butt Welding Ferrules

Size		Part Numbers		A (mm)	B (mm)	C (mm)
mm	inch	SS316	SS304			
12.7	½	L14AM7-R50	L14AM7-G50	28.70	9.40	12.70
19.05	¾	L14AM7-R75	L14AM7-G75	28.70	15.75	19.05
25.4	1	L14AM7-R100	L14AM7-G100	28.70	22.10	25.40
38.1	1½	L14AM7-R150	L14AM7-G150	28.70	34.80	38.10
50.8	2	L14AM7-R100	L14AM7-G100	28.70	47.50	50.80
63.5	2½	L14AM7-R200	L14AM7-G200	28.70	60.20	63.50
76.2	3	L14AM7-R250	L14AM7-G250	28.70	72.90	76.20
101.6	4	L14AM7-R400	L14AM7-G400	28.70	97.28	101.6
152.4	6	L14AM7-R600	L14AM7-G600	38.10	146.81	152.4
203.2	8	L14AM7-R800	L14AM7-G800	38.10	197.61	203.2
254	10	L14AM7-R1000	L14AM7-G1000	44.45	247.90	254.0
304.8	12	L14AM7-R1200	L14AM7-G1200	44.45	298.70	304.8

Product Group: AV03

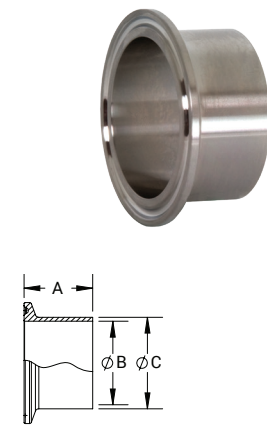

Sanitary Clamp Roll-On Ferrules

Size		Part Numbers		A (mm)	B (mm)	C (mm)
mm	inch	SS316	SS304			
25.4	1	14RMP-R100	14RMP-G100	.75	1.01	1.16
38.1	1½	14RMP-R150	14RMP-G150	1.13	1.51	1.68
50.8	2	14RMP-R200	14RMP-G200	1.31	2.01	2.19
63.5	2½	14RMP-R250	14RMP-G250	1.38	2.51	2.71
76.2	3	14RMP-R300	14RMP-G300	1.44	3.01	3.22
101.6	4	14RMP-R400	14RMP-G400	1.50	4.01	4.26

Product Group: AV03

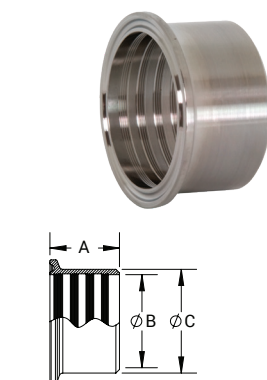

M

## Sanitary Gaskets

### Application

All elastomeric gaskets require periodic replacement. Gasket life is influenced by the gasket material, product application, temperature, cleaning procedures, etc. After monitoring gasket conditions in a process system, a schedule should be developed for the replacement of gaskets.

### Materials

- Nitrile (Buna N)
- Silicone (Peroxide cured)
- EPDM
- FKM
- PTFE

### Approvals

- US Pharmacopoeia Class VI Cytotoxicity Criteria
- Title 21CFR177.2600 & .1550
- USDA and 3A Sanitary Standards



### Colour Coding - Identification of Gasket Materials

Elastomer	Part Number Identifier	Colour Code	Temperature (celsius)
Buna-N	U	1 Red dot	-32°C to 93°C
White Buna-N	UW	1 Red dot	-32°C to 93°C
EPDM Peroxide Cured	E	3 Green dots	-34°C to 149°C
FKM	SFY	1 White dot & 1 yellow dot	-34°C to 204°C
Silicone Peroxide Cured	XW	1 Pink dot	-40°C to 232°C
Silicone Platinum Cured	XCPL	None	-40°C to 232°C
PTFE	G	None	-73°C to 260°C
Metal Detectable PTFE	GTS	None	-195°C to 288°C
Metal Detectable Buna	UZ	1 Blue dots & 1 red dot	-34°C to 93°C
Metal Detectable EPDM	EZ	2 Blue dots & 3 green dots	-34°C to 149°C
Metal Detectable FKM	SFYZ	2 Blue dots	-34°C to 204°C

### Packaging and Storing Information

The shelf life of rubber gaskets is the maximum period from the cure date to the date the product is installed. During the shelf lifetime, the rubber product is expected to retain its characteristics under the following conditions:

- Stored in the original packaging in a clean, dry warehouse
- Not exposed to direct sunlight
- Stored no closer than 6 feet from electric motors
- Temperature between 18°C to 29°C (65°F to 85°F)

A guideline for the shelf life of rubber gaskets manufactured from the following components should have the following shelf life not to exceed:

- Buna - 10 years
- EPDM - 10 years
- FKM - 10 years
- Silicone - 5 years
- PTFE - 20 years
- Buna, EPDM and Silicone Metal Detectable Gaskets - 10 years

Gaskets for Clamp Style Sanitary Fittings

Specifications

- PSI service ratings for the sanitary clamps don't apply to connections (1" and above) using any PTFE gaskets, due to the potential for cold flow under normal operating conditions. PTFE gaskets, when used with any clamp, are likely to leak at pressures far below the published service ratings. This restriction does not apply to the fractionally sized 1/2" and 3/4" connections, due to their recessed, fully contained design

Approval

- Gasket material approved by 3A, USDA and complies with FDA's 21CFR177.2600 and .1550

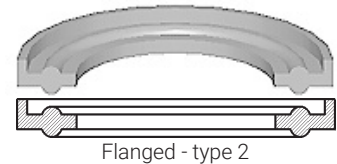
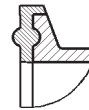
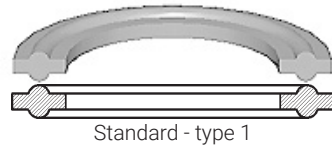
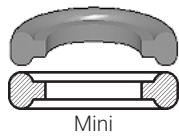

Standard Gaskets - 1/2" & 3/4"

Size		Part Numbers					
mm	inch	Buna N	EPDM	FKM	Silicone	PTFE	White Seal
12.7	1/2	42MP-U50	42MP-E50	42MP-SFY50	42MP-XCPL50	42MP-G50	42MP-EW50
19.05	3/4	42MP-U75	42MP-E75	42MP-SFY75	42MP-XCPL75	42MP-G75	42MP-EW75

Product Group: AV03



Type 1 - Standard  
1/2" & 3/4"

Standard Gaskets - 1" and Larger

Size		Part Numbers					
mm	inch	Buna N	EPDM	FKM	Silicone	PTFE	White Seal
25.4	1	40MP-U100	40MP-E100	40MP-SFY100	40MP-XCPL100	40MP-G100	-
38.1	1 1/2	40MP-U150	40MP-E150	40MP-SFY150	40MP-XCPL150	40MP-G150	-
50.8	2	40MP-U200	40MP-E200	40MP-SFY200	40MP-XCPL200	40MP-G200	40MP-EW200
63.5	2 1/2	40MP-U250	40MP-E250	40MP-SFY250	40MP-XCPL250	40MP-G250	40MP-EW250
76.2	3	40MP-U300	40MP-E300	40MP-SFY300	40MP-XCPL300	40MP-G300	40MP-EW300
101.6	4	40MP-U400	40MP-E400	40MP-SFY400	40MP-XCPL400	40MP-G400	40MP-EW400
152.4	6	40MP-U600	40MP-E600	40MP-SFY600	40MP-XCPL600	40MP-G600	40MP-EW600
203.2	8	40MP-U800	-	-	-	-	-

Product Group: AV03

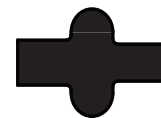

Type 1 - Standard  
1" to 12"

Flanged Gaskets - 1" and Larger

Size		Part Numbers		
mm	inch	EPDM	FKM	Silicone
25.4	1	40MPF-E100	40MPF-SFY100	40MPF-XCPL100
38.1	1 1/2	40MPF-E150	40MPF-SFY150	40MPF-XCPL150
50.8	2	40MPF-E200	40MPF-SFY200	40MPF-XCPL200
63.5	2 1/2	40MPF-E250	40MPF-SFY250	40MPF-XCPL250
76.2	3	40MPF-E300	40MPF-SFY300	40MPF-XCPL300
101.6	4	40MPF-E400	40MPF-SFY400	40MPF-XCPL400
152.4	6	40MPF-E600	40MPF-SFY600	40MPF-XCPL600
203.2	8	40MPF-E800	40MPF-SFY800	40MPF-XCPL800
254	10	40MPF-E1000	40MPF-SFY1000	40MPF-XCPL1000
304.8	12	40MPF-E1200	40MPF-SFY1200	40MPF-XCPL1200

Product Group: AV03

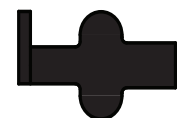

Type 2 - Flanged  
1" to 12"

Not recommended for use with bolted clamps

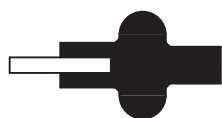

Type 3 - Mesh

## Mesh Screen Gaskets

Size		Part Numbers		
mm	inch	Buna N	EPDM	FKM
25.4	1	40MPS-U100	40MPS-E100	40MPS-SFY100
38.1	1½	40MPS-U150	40MPS-E150	40MPS-SFY150
50.8	2	40MPS-U200	40MPS-E200	40MPS-SFY200
63.5	2½	40MPS-U250	40MPS-E250	40MPS-SFY250
76.2	3	40MPS-U300	40MPS-E300	40MPS-SFY300
101.6	4	40MPS-U400	40MPS-E400	40MPS-SFY400

Product Group: AV03

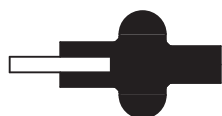

Type 3 - Perforated

## Perforated Gaskets - 0.33" Holes

Size		Part Numbers
mm	inch	Buna N
25.4	1	40MP-UP100
38.1	1½	40MP-UP150
50.8	2	40MP-UP200
63.5	2½	40MP-UP250
76.2	3	40MP-UP300
101.6	4	40MP-UP400

Product Group: AV03

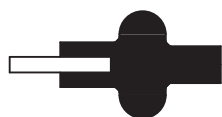

Type 3

## Orifice Gaskets - .125" Hole

Size		Part Numbers	
mm	inch	Buna N	FKM
25.4	1	A80MP-U100	A80MP-SFY100
38.1	1½	A80MP-U150	A80MP-SFY150
50.8	2	A80MP-U200	A80MP-SFY200
63.5	2½	A80MP-U250	A80MP-SFY250
76.2	3	A80MP-U300	A80MP-SFY300
101.6	4	A80MP-U400	A80MP-SFY400

Product Group: AV03



## Envelope Gaskets - PTFE

Size		Part Numbers	
mm	inch	EPDM Filler	FKM Filler
12.7	½	42MP-GRE50	42MP-GR50
19.05	¾	42MP-GRE75	42MP-GR75
25.4	1	42MP-GRE100	42MP-GR100
38.1	1½	42MP-GRE150	42MP-GR150
50.8	2	42MP-GRE200	42MP-GR200
63.5	2½	42MP-GRE250	42MP-GR250
76.2	3	42MP-GRE300	42MP-GR300
101.6	4	42MP-GRE400	42MP-GR400
152.4	6	42MP-GRE600	42MP-GR600
203.2	8	42MP-GRE800	42MP-GR800

Product Group: AV03



- PTFE is a material subject to plastic flow when cycled through heat and then cooled down in process lines, PTFE gaskets will not return to the original configuration, and it will continue to compress as the cycling continues. This plastic flow will allow leakage if clamp torques are not maintained

## Polished Butt Weld & Clamp Fittings

### Application

- Polished butt weld fittings are typically used in welded pipe systems. They are designed to provide a smooth, crevice-free connection between two pieces of stainless steel or other compatible materials.

### Material

- Polished 316L stainless steel
- 304 stainless steel

### Approval

- AS1528.3:2019

### Butt Weld Concentric Reducer - AS1528.3

Size		Part Numbers		A (mm)	Nominal Wall (mm)
mm	inch	SS316	SS304		
19.05 x 12.7	¾ x ½	B31W-R7550PA	B31W-G7550PA	19.05	1.6
25.4 x 12.7	1 x ½	B31W-R10050PA	B31W-G10050PA	25.40	1.6 or 2
25.4 x 19.05	1 x ¾	B31W-R10075PA	B31W-G10075PA	25.40	1.6 or 2
38.1 x 12.7	1½ x ½	B31W-R15050PA	B31W-G15050PA	38.10	1.6 or 2
38.1 x 19.05	1½ x ¾	B31W-R15075PA	B31W-G15075PA	38.10	1.6 or 2
38.1 x 25.4	1½ x 1	B31W-R150100PA	B31W-G150100PA	38.10	1.6 or 2
50.8 x 12.7	2 x ½	B31W-R20050PA	-	50.80	1.6 or 2
50.8 x 19.05	2 x ¾	B31W-R20075PA	-	50.80	1.6 or 2
50.8 x 25.4	2 x 1	B31W-R200100PA	B31W-G200100PA	50.80	1.6 or 2
50.8 x 38.1	2 x 1½	B31W-R200150PA	B31W-G200150PA	50.80	1.6 or 2
63.5 x 25.4	2½ x 1	B31W-R250100PA	B31W-G250100PA	63.50	1.6 or 2
63.5 x 38.1	2½ x 1½	B31W-R250150PA	B31W-G250150PA	63.50	1.6 or 2
63.5 x 50.8	2½ x 2	B31W-R250200PA	B31W-G250200PA	63.50	1.6 or 2
76.2 x 25.4	3 x 1	B31W-R300100PA	B31W-G300100PA	76.20	1.6 or 2
76.2 x 38.1	3 x 1½	B31W-R300150PA	B31W-G300150PA	76.20	1.6 or 2
76.2 x 50.8	3 x 2	B31W-R300200PA	B31W-G300200PA	76.20	1.6 or 2
76.2 x 63.5	3 x 2½	B31W-R300250PA	B31W-G300250PA	76.20	1.6 or 2
101.6 x 38.1	4 x 1½	B31W-R400150PA	B31W-G400150PA	101.6	1.6 or 2
101.6 x 50.4	4 x 2	B31W-R400200PA	B31W-G400200PA	101.6	1.6 or 2
101.6 x 63.5	4 x 2½	B31W-R400250PA	B31W-G400250PA	101.6	1.6 or 2
101.6 x 76.2	4 x 3	B31W-R400300PA	B31W-G400300PA	101.6	1.6 or 2
152.4 x 50.8	6 x 2	B31W-R600200PA	B31W-G600200PA	152.4	1.6 or 2
152.4 x 76.2	6 x 3	B31W-R600300PA	B31W-G600300PA	152.4	1.6 or 2
152.4 x 101.6	6 x 4	B31W-R600400PA	B31W-G600400PA	152.4	1.6 or 2
203.2 x 101.6	8 x 4	B31W-R800400PA	B31W-G800400PA	203.2	1.6, 2 or 2.5
203.2 x 152.4	8 x 6	B31W-R800600PA	B31W-G800600PA	203.2	1.6, 2 or 2.5

Product Group: AV08

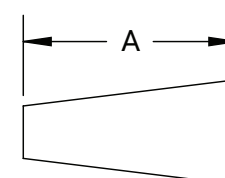

AS 1528.3:2019

### 90° Butt Weld Elbows with Tangents - AS1528.3

Size		Part Numbers		A (mm)	R (mm)	Nominal Wall (mm)
mm	inch	SS316	SS304			
12.70	½	B2S-R50PA	B2S-G50PA	49.05	19.05	1.6
19.05	¾	B2S-R75PA	B2S-G75PA	58.58	28.58	1.6
25.40	1	B2S-R100PA	B2S-G100PA	68.10	38.10	1.6 or 2
38.10	1½	B2S-R150PA	B2S-G150PA	87.15	57.15	1.6 or 2
50.80	2	B2S-R200PA	B2S-G200PA	106.2	76.20	1.6 or 2
63.50	2½	B2S-R250PA	B2S-G250PA	125.25	95.25	1.6 or 2
76.20	3	B2S-R300PA	B2S-G300PA	144.3	114.3	1.6 or 2
101.6	4	B2S-R400PA	B2S-G400PA	182.4	152.4	1.6 or 2
152.4	6	B2S-R600PA	B2S-G600PA	268.6	228.6	1.6 or 2

Product Group: AV08

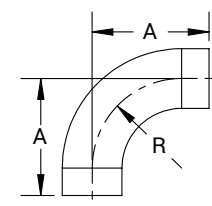

AS 1528.3:2019



## 45° Butt Weld Elbows with Tangents - AS1528.3

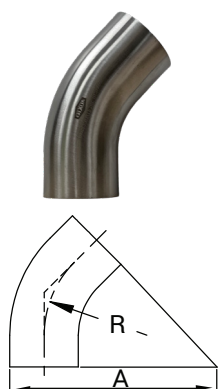

AS 1528.3:2019

Size		Part Numbers		A (mm)	R (mm)	Nominal Wall (mm)
mm	inch	SS316	SS304			
12.70	½	B2KS-R50PA	B2KS-G50PA	97.90	19.05	1.6
19.05	¾	B2KS-R75PA	B2KS-G75PA	110.6	28.58	1.6
25.40	1	B2KS-R100PA	B2KS-G100PA	123.2	38.10	1.6 or 2
38.10	1½	B2KS-R150PA	B2KS-G150PA	148.7	57.15	1.6 or 2
50.80	2	B2KS-R200PA	B2KS-G200PA	174.1	76.20	1.6 or 2
63.50	2½	B2KS-R250PA	B2KS-G250PA	199.5	95.25	1.6 or 2
76.20	3	B2KS-R300PA	B2KS-G300PA	224.9	114.3	1.6 or 2
101.6	4	B2KS-R400PA	B2KS-G400PA	275.7	152.4	1.6 or 2

Product Group: AV08

## Polished Eccentric Weld Reducer - AS1528.3

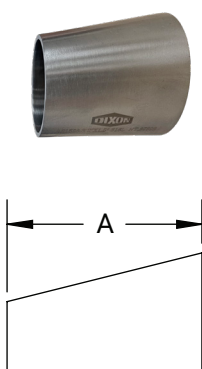

AS 1528.3:2019

Size		Part Numbers		A (mm)	Nominal Wall (mm)
mm	inch	SS316	SS304		
19.05 x 12.7	¾ x ½	B32W-R7550PA	-	19.05	1.6
25.4 x 12.7	1 x ½	B32W-R10050PA	-	25.40	1.6 or 2
25.4 x 19.05	1 x ¾	B32W-R10075PA	-	25.40	1.6 or 2
38.1 x 12.7	1½ x ½	B32W-R15050PA	-	38.10	1.6 or 2
38.1 x 19.05	1½ x ¾	B32W-R15075PA	-	38.10	1.6 or 2
38.1 x 25.4	1½ x 1	B32W-R150100PA	B32W-G150100PA	38.10	1.6 or 2
50.8 x 12.7	2 x ½	B32W-R20050PA	-	50.80	1.6 or 2
50.8 x 19.05	2 x ¾	B32W-R20075PA	-W	50.80	1.6 or 2
50.8 x 25.4	2 x 1	B32W-R200100PA	B32W-G200100PA	50.80	1.6 or 2
50.8 x 38.1	2 x 1½	B32W-R200150PA	B32W-G200150PA	50.80	1.6 or 2
63.5 x 38.1	2½ x 1½	B32W-R250150PA	B32W-G250150PA	63.50	1.6 or 2
63.5 x 50.8	2½ x 2	B32W-R250200PA	B32W-G250200PA	63.50	1.6 or 2
76.2 x 25.4	3 x 1	B32W-R300100PA	B32W-G300100PA	76.20	1.6 or 2
76.2 x 38.1	3 x 1½	B32W-R300150PA	B32W-G300150PA	76.20	1.6 or 2
76.2 x 50.8	3 x 2	B32W-R300200PA	B32W-G300200PA	76.20	1.6 or 2
76.2 x 63.5	3 x 2½	B32W-R300250PA	B32W-G300250PA	76.20	1.6 or 2
101.6 x 38.1	4 x 1½	B32W-R400150PA	B32W-G400150PA	101.6	1.6 or 2
101.6 x 50.4	4 x 2	B32W-R400200PA	B32W-G400200PA	101.6	1.6 or 2
101.6 x 63.5	4 x 2½	B32W-R400250PA	B32W-G400250PA	101.6	1.6 or 2
101.6 x 76.2	4 x 3	B32W-R400300PA	B32W-G400300PA	101.6	1.6 or 2
152.4 x 76.2	6 x 3	B32W-R600300PA	B32W-G600300PA	152.4	1.6 or 2
152.4 x 101.6	6 x 4	B32W-R600400PA	B32W-G600400PA	152.4	1.6 or 2
203.2 x 101.6	8 x 4	B32W-R800400PA	B32W-G800400PA	203.2	1.6, 2 or 2.5
203.2 x 152.4	8 x 6	B32W-R800600PA	B32W-G800600PA	203.2	1.6, 2 or 2.5

Product Group: AV08

## Butt Weld Long Tee - AS1528.3

Size		Part Numbers		A (mm)	Nominal Wall (mm)
mm	inch	SS316	SS304		
12.70	½	B7W-R50PA	B7W-G50PA	19.05	1.6
19.05	¾	B7W-R75PA	B7W-G75PA	28.58	1.6
25.40	1	B7W-R100PA	B7W-G100PA	38.10	1.6 or 2
38.10	1½	B7W-R150PA	B7W-G150PA	57.15	1.6 or 2
50.80	2	B7W-R200PA	B7W-G200PA	76.20	1.6 or 2
63.50	2½	B7W-R250PA	B7W-G250PA	95.25	1.6 or 2
76.20	3	B7W-R300PA	B7W-G300PA	114.3	1.6 or 2
101.6	4	B7W-R400PA	B7W-G400PA	152.4	1.6 or 2
152.4	6	B7W-R600PA	B7W-G600PA	228.6	1.6 or 2

Product Group: AV08

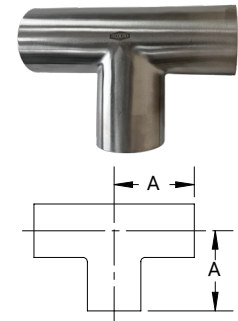

AS 1528.3:2019

## Butt Weld Reducing Tee - AS1528.3

Size		Part Numbers		A (mm)	Nominal Wall (mm)
mm	inch	SS316	SS304		
19.05 x 12.7	¾ x ½	B7RWWW-R7550PA	-	19.05	1.6
25.4 x 12.7	1 x ½	B7RWWW-R10050PA	-	28.58	1.6 or 2
25.4 x 19.05	1 x ¾	B7RWWW-R10075PA	-	28.58	1.6 or 2
38.1 x 12.7	1½ x ½	B7RWWW-R15050PA	-	47.63	1.6 or 2
38.1 x 19.05	1½ x ¾	B7RWWW-R15075PA	-	47.63	1.6 or 2
38.1 x 25.4	1½ x 1	B7RWWW-R150100PA	B7RWWW-G150100PA	47.63	1.6 or 2
50.8 x 25.4	2 x 1	B7RWWW-R200100PA	B7RWWW-G200100PA	57.15	1.6 or 2
50.8 x 38.1	2 x 1½	B7RWWW-R200150PA	B7RWWW-G200150PA	57.15	1.6 or 2
63.5 x 38.1	2½ x 1½	B7RWWW-R250150PA	B7RWWW-G250150PA	76.20	1.6 or 2
63.5 x 50.8	2½ x 2	B7RWWW-R250200PA	B7RWWW-G250200PA	76.20	1.6 or 2
76.2 x 38.1	3 x 1½	B7RWWW-R300150PA	B7RWWW-G300150PA	95.25	1.6 or 2
76.2 x 50.8	3 x 2	B7RWWW-R300200PA	B7RWWW-G300200PA	95.25	1.6 or 2
76.2 x 63.5	3 x 2½	B7RWWW-R300250PA	B7RWWW-G300250PA	92.25	1.6 or 2
101.6 x 38.1	4 x 1½	B7RWWW-R400150PA	B7RWWW-G400150PA	114.3	1.6 or 2
101.6 x 50.4	4 x 2	B7RWWW-R400200PA	B7RWWW-G400200PA	114.3	1.6 or 2
101.6 x 63.5	4 x 2½	B7RWWW-R400250PA	B7RWWW-G400250PA	114.3	1.6 or 2
101.6 x 76.2	4 x 3	B7RWWW-R400300PA	B7RWWW-G400300PA	114.3	1.6 or 2
152.4 x 50.4	6 x 2	B7RWWW-R600200PA	B7RWWW-G600200PA	190.5	1.6 or 2
152.4 x 76.2	6 x 3	B7RWWW-R600300PA	B7RWWW-G600300PA	190.5	1.6 or 2
152.4 x 101.6	6 x 4	B7RWWW-R600400PA	B7RWWW-G600400PA	190.5	1.6 or 2

Product Group: AV08

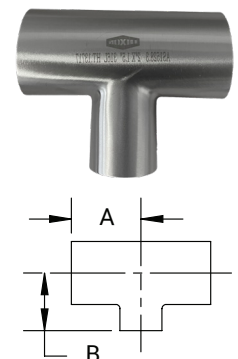

AS 1528.3:2019

## 45° Clamp Elbows

Size		Part Numbers		A (mm)	R (mm)
mm	inch	SS316	SS304		
12.7	½	B2KMP-R50	-	24.6	28.7
19.05	¾	B2KMP-R75	-	24.6	28.7
25.4	1	B2KMP-R100	B2KMP-G100	24.4	38.1
38.1	1½	B2KMP-R150	B2KMP-G150	36.5	57.1
50.8	2	B2KMP-R200	B2KMP-G200	44.4	76.2
63.5	2½	B2KMP-R250	B2KMP-G250	52.3	95.2
76.2	3	B2KMP-R300	B2KMP-G300	60.2	114.3
101.6	4	B2KMP-R400	B2KMP-G400	79.5	152.4
152.4	6	B2KMP-R600	B2KMP-G600	117.6	228.6

Product Group: AV08

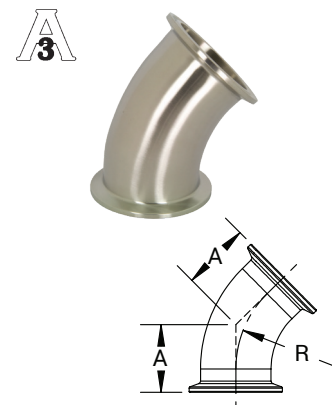

# Hygienic Fittings

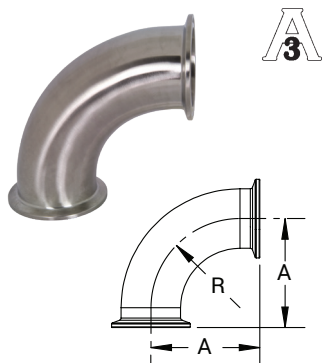

## 90° Clamp Elbows

Size		Part Numbers		A (mm)	R (mm)
mm	inch	SS316	SS304		
12.7	½	B2CMP-R50	-	41.4	28.7
19.05	¾	B2CMP-R75	-	41.4	28.7
25.4	1	B2CMP-R100	B2CMP-G100	50.4	38.1
38.1	1½	B2CMP-R150	B2CMP-G150	69.8	57.1
50.8	2	B2CMP-R200	B2CMP-G200	88.9	76.2
63.5	2½	B2CMP-R250	B2CMP-G250	107.9	95.25
76.2	3	B2CMP-R300	B2CMP-G300	127.0	114.3
101.6	4	B2CMP-R400	B2CMP-G400	168.4	152.4
152.4	6	B2CMP-R600	B2CMP-G600	250.9	228.6

Product Group: AV08

## Clamp Tees

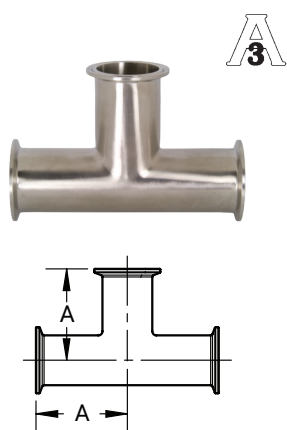

Size		Part Numbers		A (mm)
mm	inch	SS316	SS304	
12.7	½	B7MP-R50	-	60.45
19.05	¾	B7MP-R75	-	63.50
25.4	1	B7MP-R100	B7MP-G100	60.45
38.1	1½	B7MP-R150	B7MP-G150	69.85
50.8	2	B7MP-R200	B7MP-G200	88.90
63.5	2½	B7MP-R250	B7MP-G250	88.90
76.2	3	B7MP-R300	B7MP-G300	95.25
101.6	4	B7MP-R400	B7MP-G400	114.3
152.4	6	B7MP-R600	B7MP-G600	165.1

Product Group: AV08

## Clamp Concentric Reducers

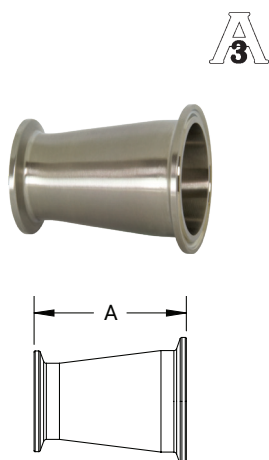

Size		Part Numbers		A (mm)
mm	inch	SS316	SS304	
19.05 x 12.7	¾ x ½	B3114MP-R7550	-	50.8
25.4 x 12.7	1 x ½	B3114MP-R10050	-	76.2
25.4 x 19.05	1 x ¾	B3114MP-R10075	-	50.8
38.1 x 12.7	1½ x ½	B3114MP-R15050	-	127.0
38.1 x 19.05	1½ x ¾	B3114MP-R15075	-	101.6
38.1 x 25.4	1½ x 1	B3114MP-R150100	B3114MP-G150100	76.2
50.8 x 12.7	2 x ½	B3114MP-R20050	-	177.8
50.8 x 19.05	2 x ¾	B3114MP-R20075	-	152.4
50.8 x 25.4	2 x 1	B3114MP-R200100	B3114MP-G200100	127.0
50.8 x 38.1	2 x 1½	B3114MP-R200150	B3114MP-G200150	76.2
63.5 x 38.1	2½ x 1½	B3114MP-R250150	B3114MP-G250150	127.0
63.5 x 50.8	2½ x 2	B3114MP-R250200	B3114MP-G250200	76.2
76.2 x 25.4	3 x 1	B3114MP-R300100	B3114MP-G300100	228.6
76.2 x 38.1	3 x 1½	B3114MP-R300150	B3114MP-G300150	177.8
76.2 x 50.8	3 x 2	B3114MP-R300200	B3114MP-G300200	127.0
76.2 x 63.5	3 x 2½	B3114MP-R300250	B3114MP-G300250	76.2
101.6 x 38.1	4 x 1½	B3114MP-R400150	B3114MP-G400150	282.7
101.6 x 50.4	4 x 2	B3114MP-R400200	B3114MP-G400200	231.9
101.6 x 63.5	4 x 2½	B3114MP-R400250	B3114MP-G400250	181.1
101.6 x 76.2	4 x 3	B3114MP-R400300	B3114MP-G400300	130.3
152.4 x 50.8	6 x 2	B3114MP-R600200	B3114MP-G600200	174.7
152.4 x 76.2	6 x 3	B3114MP-R600300	B3114MP-G600300	174.7
152.4 x 101.6	6 x 4	B3114MP-R600400	B3114MP-G600400	177.8
203.2 x 101.6	8 x 4	B3114MP-R800400	B3114MP-G800400	190.5
203.2 x 152.4	8 x 6	B3114MP-R800600	B3114MP-G800600	196.8

Product Group: AV08

BSP Tube Adaptors - Stainless Steel

Size		Part Numbers	A (mm)	Nominal Wall (mm)
mm	inch			
12.7	½	B19WB-R50A	41.4	1.6
19.05	¾	B19WB-R75A	41.4	1.6
25.4	1	B19WB-R100A	44.4	1.6
38.1	1½	B19WB-R150A	44.4	1.6
50.8	2	B19WB-R200A	45.9	1.6
63.5	2½	B19WB-R250A	58.6	1.6
76.2	3	B19WB-R300A	63.5	1.6
101.6	4	B19WB-R400A	65.0	2.1

Product Group: AV08

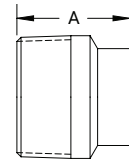

Sight Glass - Stainless Steel

Size		Part Numbers		Working Pressure (PSI)
mm	inch	Weld - EPDM	Clamp - Buna N	
25.4	1	B54EBB-R100	B54BMP-R100	145
38.1	1½	B54EBB-R150	B54BMP-R150	145
50.8	2	B54EBB-R200	B54BMP-R200	145
63.5	2½	B54EBB-R250	B54BMP-R250	120
76.2	3	B54EBB-R300	B54BMP-R300	120
101.6	4	B54EBB-R400	B54BMP-R400	95
152.4	6	B54EBB-R600	B54BMP-R600	80

Product Group: AV09



Weld

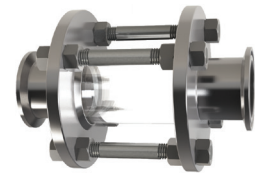

Clamp

Replacement Glass - Borosilicate

Size		Part Numbers
mm	inch	
25.4	1	B54G-P100
38.1	1½	B54G-P150
50.8	2	B54G-P200
63.5	2½	B54G-P250
76.2	3	B54G-P300
101.6	4	B54G-P400

Product Group: AV09



Sight Glass Lens Dimensions

Size		OD (+/- 1/5mm)	ID (+/- 1.5mm)	Length (+/- 1.5mm)
mm	inch			
25.4	1	31	22	63.5
38.1	1 1/2	44	35	63.5
50.8	2	58	48	63.5
63.5	2 1/2	71	59	71
76.2	3	88	72	100
101.6	4	116	97	100

# Hygienic Fittings

## Compact Sight Glasses

### Application

- Used widely in the food, dairy and beverage sanitary processes to view products and fluids. This design is perfect for hoses.

### Features

- Easier to clean than bolted styles
- Less cost to repair than bolted styles
- Clamp connections standard
- Sizes available: 25mm (1"), 38mm (1 1/2"), 50mm (2"), 80mm (3")
- Maximum Temperature: 95°C
- Maximum Pressure: 6.9 bar

### Material

- Body: 316L stainless steel
- Sight Glass: borosilicate glass
- Gasket: Nitrile buna rubber

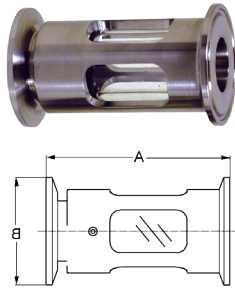

Size		Part Numbers	A (mm)	B (mm)
mm	inch			
25.4	1	B54BMPS-R100	85.73	50.30
38.1	1 1/2	B54BMPS-R150	92.46	50.30
50.8	2	B54BMPS-R200	97.28	64.00
76.2	3	B54BMPS-R300	104.90	96.52
101.6	4	B54BMPS-R400	110.24	118.87

Product Group: AV09

### Kits and Replacement Parts



Size		Part Numbers	
mm	inch	Seal Kit	Replacement Glass
25.4	1	B54BMPS-SK100	B54BMPS-GL100
38.1	1 1/2	B54BMPS-SK150	B54BMPS-GL150
50.8	2	B54BMPS-SK200	B54BMPS-GL200
76.2	3	B54BMPS-SK300	B54BMPS-GL300
101.6	4	B54BMPS-SK400	B54BMPS-GL400

Product Group: AV09

## Clamp Spray Ball - Rotating

### Specifications

- Ideal for cleaning all types of tanks and vessels

### Features

- Stainless steel ball bearings eliminate rust
- Cleaning solution lubricates unit
- Mirror-like finish (OD)
- Spray pattern 360°

### Material

- Body: 316L stainless steel



Size		Part Number	A (mm)	B (mm)	C (mm)
mm	inch				
38.1	1 1/2	SRH360CMP-R150	138.9	52.5	38.1

Product Group: AV13

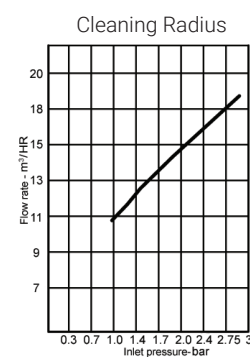
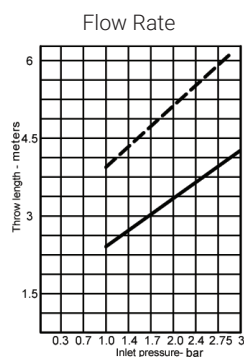

## Spray Balls

### Specifications

- Typical use is in food and beverage industries for cleaning storage tanks

### Features

- Heavy stainless steel construction provides longer life
- Various spray patterns available
- Stationary, designed to be mounted to a tube or pipe
- 2mm spray holes

### Material

- Body: 316L stainless steel

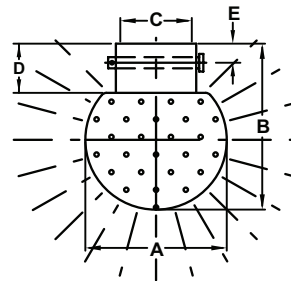
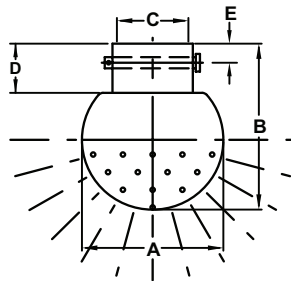
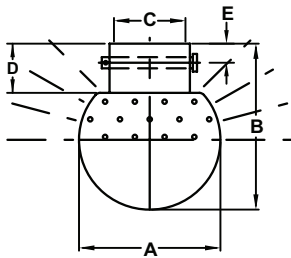

Size		Part Numbers	Pin Length	Spray Pattern	Dimensions					Pin Size
mm	inch				A	B	C	D	E	
25.4	1	STC-360-R100	1.47	360°	90	75	25	25	11	5.7
38.1	1½	STC-360-R150	1.95	360°	90	75	38	25	11	5.7
25.4	1	STC-360-R100	1.47	180° Bottom	90	75	25	25	11	5.7
38.1	1½	STC-360-R150	1.95	180° Bottom	90	75	38	25	11	5.7
25.4	1	STC-360-R100	1.47	180° Top	90	75	25	25	11	5.7
38.1	1½	STC-360-R150	1.95	180° Top	90	75	38	25	11	5.7

Product Group: AV09

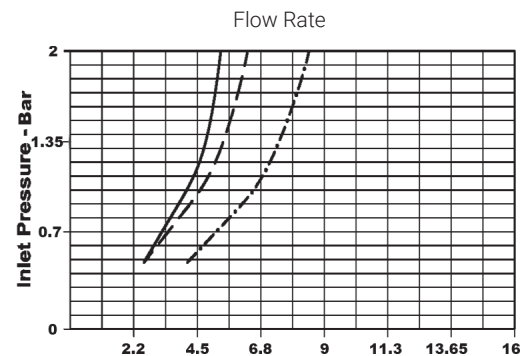
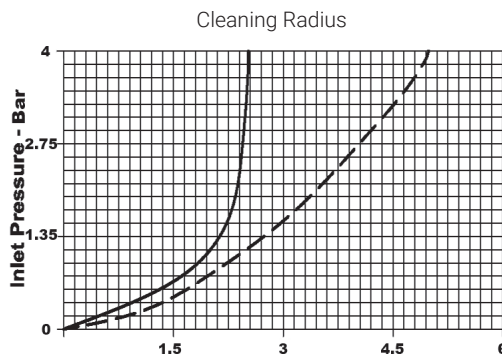

## Butt Weld Tube End Adaptors and Couplers

### Material

- Body: 316 stainless steel

Size		Part Numbers	
mm	inch	Adaptors	Boss-Lock™ Couplers
25.4	1	RE100BT	RC100BT
38.1	1½	RE150BT	RC150BT
50.8	2	RE200BT	RC200BT
76.2	3	RE300BT	RC300BT

Designed to be butt welded to standard sanitary tubing

Product Group: AL10



Adaptor



Coupler

# Hygienic Fittings

## SJSS Swivel Series

### Application

- A range of combination swivel joints are available to assist with moving hoses through process lines and keeping hoses away from machinery and forklifts. All joints meet food and beverage industry certification standards.

### Features

- Longer inner body for easier repair kit insertion
- Large chamber for a rapid, smooth assembly

### Material

- Product Contact Components: 316L stainless steel
- Non-Product Contact Components: 304 stainless steel
- Gaskets: PTFE and silicone available

### Approval

- 3A certified

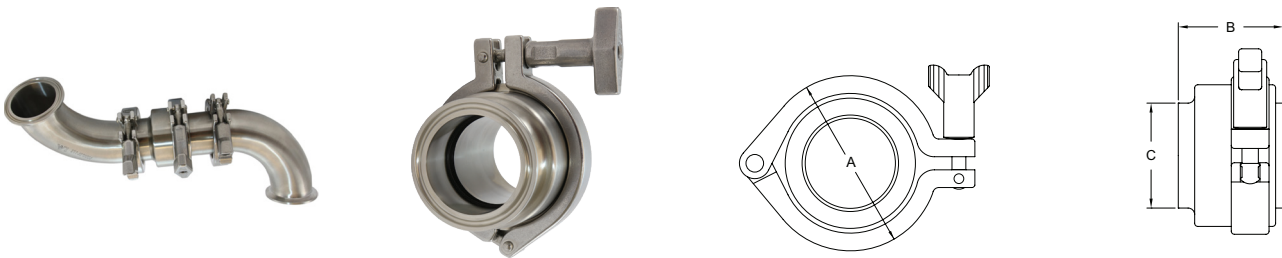

Tube OD Size		Part Numbers	Dimensions			PSI at 21°C	PSI at 121°C	Torque (in lbs)
mm	inch		A	B	C			
25.4	1	SJSS100EBB120	65	50.8	25.4	500	300	300
38.1	1½	SJSS150EBB120	65	50.8	38.1	500	300	300
50.8	2	SJSS200EBB120	78.49	50.8	50.8	450	250	250
63.5	2½	SJSS250EBB120	87.34	50.8	63.5	400	200	200
76.2	3	SJSS300EBB120	100.08	50.8	76.2	350	175	175
101.6	4	SJSS400EBB120	129.03	74.68	101.6	300	150	150

Product Group: AV13

## Sanitary Breakaway Couplings

### Application

- Minimises spillage and damage associated with pull-away and drive-away incidents. Coupling breaks away with an excessive load.

### Features

- Designed to be installed between a fixed point and a hose
- 24kN break load bolts standard, other break loads available

### Material

- Coupling: 316 stainless steel polished to standard <0.8Ra µm, 3A finish
- Clamp Gasket: white EPDM standard, optional material available



Size		Part Numbers
mm	inch	
50.8	2	SBC-200BBE-13
63.5	2½	SBC-250BBE-13
76.2	3	SBC-300BBE-13
101.6	4	SBC-400BBE-13

Product Group: AV02



## Holedall™ BSM (RJT) External Crimp Stem

### Standards

- RJT (BSM) AS 1528.2 - 2001: screwed couplings

### Material

- 316 stainless steel

Size		Part Numbers	
mm	inch	Female	Male
25.4	1	HA0224	HA0219
38.1	1½	HA0225	HA0220
50.8	2	HA0226	HA0221
63.5	2½	HA0227	HA0222
76.2	3	HA0228	HA0223
101.6	4	HA0294	HA0293

All stems are manufactured to suit inch bore hoses (not metric hose bores)

Product Group: AV07



Female



Male

## Holedall™ SMS External Crimp Stem

### Material

- 316 stainless steel

Size		Part Numbers	
mm	inch	Female	Male
25.4	1	HA0616	HA0622
38.1	1½	HA0617	HA0623
50.8	2	HA0618	HA0624
63.5	2½	HA0619	HA0625
76.2	3	HA0620	HA0626
101.6	4	HA0621	HA0627

All stems are manufactured to suit inch bore hoses (not metric hose bores)

Product Group: AV07



Female



Male

## Holedall™ Clamp Type/External Crimp Stem

### Material

- 316 stainless steel

Size		Part Numbers
mm	inch	Male
25.4	1	HA0640
38.1	1½	HA0641
50.8	2	HA0642
63.5	2½	HA0643
76.2	3	HA0644
101.6	4	HA0645

All stems are manufactured to suit inch bore hoses (not metric hose bores)

Product Group: AV07



## Holedall™ DIN External Crimp Stem

### Material

- 316 stainless steel

### Standards

- DIN 11851/11887 couplings and gaskets



Female



Male

Size DN		Part Numbers	
mm	inch	Female	Male
25.4	1	HA0239	HA0234
38.1	1½	HA0240	HA0235
50.8	2	HA0241	HA0236
63.5	2½	HA0242	HA0237
76.2	3	HA0243	HA0238
101.6	4	HA0298	HA0297

All stems are manufactured to suit inch bore hoses (not metric bore hoses)

Product Group: AV07

## Holedall™ External Crimp Ferrules

### Material

- 304 stainless steel

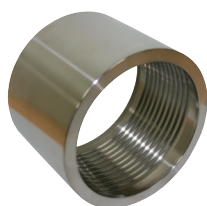

Size		Part Numbers	Hose OD (mm)	
mm	inch		from	to
25.4	1	HA0249-41-3	33.0	35.0
25.4	1	HA0249-43-3	35.7	36.5
25.4	1	HA0249-45-3	36.9	37.7
25.4	1	HA0249-46-3	38.1	38.9
25.4	1	HA0249-47-3	39.3	40.1
25.4	1	HA0249-48-3	40.5	41.3
38.1	1½	HA0250-56-3	48.4	49.6
38.1	1½	HA0250-58-3	50.0	51.2
38.1	1½	HA0250-59-3	51.6	52.8
38.1	1½	HA0250-61-3	53.2	54.4
38.1	1½	HA0250-63-3	56.4	57.6
50.8	2	HA0251-70-3	62.7	63.9
50.8	2	HA0251-72-3	64.3	65.5
50.8	2	HA0251-74-3	65.9	67.1
50.8	2	HA0251-75-3	67.4	68.7
50.8	2	HA0251-76-3	71.4	73.6
63.5	2½	HA0252-84-3	76.1	78.1
63.5	2½	HA0252-86-3	78.1	80.1
63.5	2½	HA0252-89-3	81.1	83.1
76.2	3	HA0253-96-3	88.0	91.0
76.2	3	HA0253-98-3	91.7	92.9
76.2	3	HA0253-100-3	92.1	93.3
76.2	3	HA0253-101-3	93.6	94.9
76.2	3	HA0253-103-3	95.2	96.5
76.2	3	HA0253-105-3	96.8	98.0
76.2	3	HA0253-106-3	98.4	99.6
76.2	3	HA0253-107-3	100.4	101.6
101.6	4	HA0301-129-3	117.5	118.7
101.6	4	HA0301-130-3	119.0	120.3
101.6	4	HA0301-132-3	120.6	121.9
101.6	4	HA0301-133-3	122.2	123.5
101.6	4	HA0301-135-3	123.8	125.0
101.6	4	HA0301-136-3	128.9	130.18

Product Group: AV07

### Wine Female Crimp Stem

**Material**

- 316 stainless steel

Size		Part Numbers
mm	inch	
50.8	2	HA0850
76.2	3	HA0851
101.6	4	HA0297

Product Group: AV07



### Butt Weld Tube Crimp Stem

**Material**

- 316 stainless steel

Size		Part Numbers
mm	inch	
25.4	1	HA0833
38.1	1½	HA0835
50.8	2	HA0837
63.5	2½	HA0839
76.2	3	HA0841
101.6	4	HA0843

Product Group: AV07

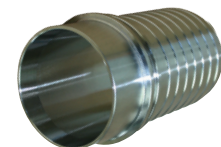

### BSM CIP Crimp Stem

**Material**

- 316 stainless steel

Size		Part Numbers
mm	inch	
25.4	1	HA0224-CIP
38.1	1½	HA0225-CIP
50.8	2	HA0226-CIP
63.5	2½	HA0227-CIP
76.2	3	HA0228-CIP
101.6	4	HA0229-CIP

Product Group: AV07

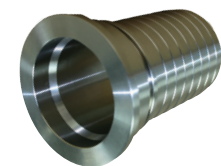

### Inline Hose Strainer

**Material**

- 316 stainless steel

Size		Part Number
mm	inch	
76.2	3	HS-R300

Product Group: AV07



### NZ RJT Crimp Stem

**Material**

- 316 stainless steel

Size		Part Numbers
mm	inch	
38.1	1½	HA0225-NZ
50.8	2	HA0226-NZ
63.5	2½	HA0227-NZ
76.2	3	HA0228-NZ
101.6	4	HA0294-NZ

Product Group: AV07

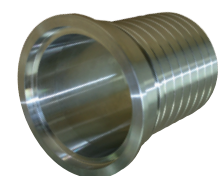

## Dixon™ Sanitary King Crimp™ Stems

### Application

- Our Sanitary King Crimp Stems are meticulously designed for seamless use in food and beverage applications. The internal smooth bore ensures a hygienic environment, promoting the highest standards of cleanliness. These stems are lightweight yet robust, making them an excellent choice for various applications. Not only can they be used with Dixon's King Crimp™ ferrules, but they also integrate effortlessly with both PVC and rubber hoses.

### Material

- 316 stainless steel



### Clamp End x Hose Tail

Size		Part Numbers
mm	inch	
25.4	1	CSSR100CS
38.1	1½	CSSR150CS
50.8	2	CSSR200CS
76.2	3	CSSR300CS
101.6	4	CSSR400CS

Product Group: AV07

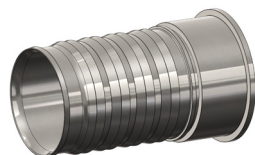

### RJT x Hose Tail

Size		Part Numbers
mm	inch	
25.4	1	HA0224-KC
38.1	1½	HA0225-KC
50.8	2	HA0226-KC
63.5	2½	HA0227-KC
76.2	3	HA0228-KC
101.6	4	HA0294-KC

Product Group: AV07



### NZ RJT x Hose Tail

Size		Part Numbers
mm	inch	
38.1	1½	HA0225-NZKC
50.8	2	HA0226-NZKC
63.5	2½	HA0227-NZKC
76.2	3	HA0228-NZKC
101.6	4	HA0294-NZKC

Product Group: AV07



### CIP Flat Face x Hose Tail

Size		Part Numbers
mm	inch	
25.4	1	HA0224-CIPKC
38.1	1½	HA0225-CIPKC
50.8	2	HA0226-CIPKC
63.5	2½	HA0227-CIPKC
76.2	3	HA0228-CIPKC
101.6	4	HA0294-CIPKC

Product Group: AV07

All Dixon™ Sanitary King Crimp™ stems are used with King Crimp™ light weight ferrules and can also be used with standard ferrules & sleeves

## Wine x Hose Tail

Size		Part Numbers
mm	inch	
50.8	2	HA0850-KC
76.2	3	HA0851-KC
101.6	4	HA0852-KC

Product Group: AV07

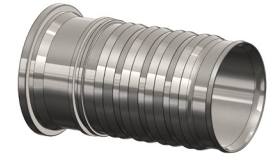

## Weld End x Hose Tail

Size		Part Numbers
mm	inch	
25.4	1	HA0833-KC
38.1	1½	HA0835-KC
50.8	2	HA0837-KC
63.5	2½	HA0839-KC
76.2	3	HA0841-KC
101.6	4	HA0843-KC

Product Group: AV07



## DIN 11851 x Hose Tail

Size		Part Numbers
mm	inch	
25.4	1	HA0239-KC
38.1	1½	HA0240-KC
50.8	2	HA0241-KC
63.5	2½	HA0242-KC
76.2	3	HA0243-KC
101.6	4	HA0234-KC

All Dixon™ Sanitary King Crimp™ stems are used with King Crimp™ light weight ferrules and can also be used with standard ferrules & sleeves

Product Group: AV07

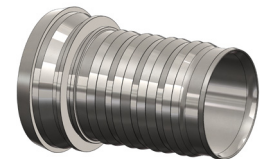

M

## Light Weight External King Crimp™ Ferrules

### Material

- 304 stainless steel

Size		Part Numbers	Hose OD (mm)	
mm	inch		from	to
25.4	1	CF100-038SS	36.0	39.1
25.4	1	CF100-043SS	38.0	43.5
38.1	1½	CF150-052SS	48.0	52.8
38.1	1½	CF150-056SS	52.0	56.4
50.8	2	CF200-064SS	61.0	67.0
50.8	2	CF200-069SS	64.0	71.4
63.5	2½	CF250-078SS	73.0	80.7
63.5	2½	CF250-081SS	78.0	83.5
76.2	3	CF300-091SS	86.0	93.6
76.2	3	CF300-096SS	91.0	98.0
101.6	4	CF400-119SS	114.0	121.1
101.6	4	CF400-124SS	119.0	125.5

Product Group: AV07



# Hygienic Fittings

## 14-SHB-Series Sanitary Hose Bumper

Dixon's 14-SHB-series hose bumper is an innovative departure from traditional rubber bumpers. It prevents forced detachment from the crimp stem even when dragged or dropped on the ground. The open design ensures easy access to clean all surfaces of the fitting while completely protecting the hose ferrule. Experience the convenience and assurance of this hose bumper – slide with ease, secure with confidence!

### Application

- Constructed of durable polypropylene, this sanitary hose bumper meets the FDA CFR 21 standard for use in the food, beverage, dairy, winery and brewery, cosmetic, and pharmaceutical markets.

### Sizes

- 1", 1-1/2", 2", 3"

### Features

- No special tools or fasteners needed for installation
- Patent-pending two-position design provides complete protection to sanitary tri-clamp ferrule
- Cannot be forced off crimp stem like most traditional rubber bumpers when dragged on the ground
- The open design maintains clearance between the crimp stem and the bumper allowing for access to clean and drain all surfaces of the stainless steel fitting
- One bumper size works with any hose diameter within a given tri-clamp ferrule size
- The bumper and sanitary crimp stem were designed together as a system to ensure optimal performance
- Polypropylene bumper contains Sanafor PO-5 antimicrobial additive

### Specifications

- Materials of construction
  - Bumper: Polypropylene with an antimicrobial additive (FDA approved)
  - Latch: EPDM (FDA approved)
  - Crimp stem: AISI 316L

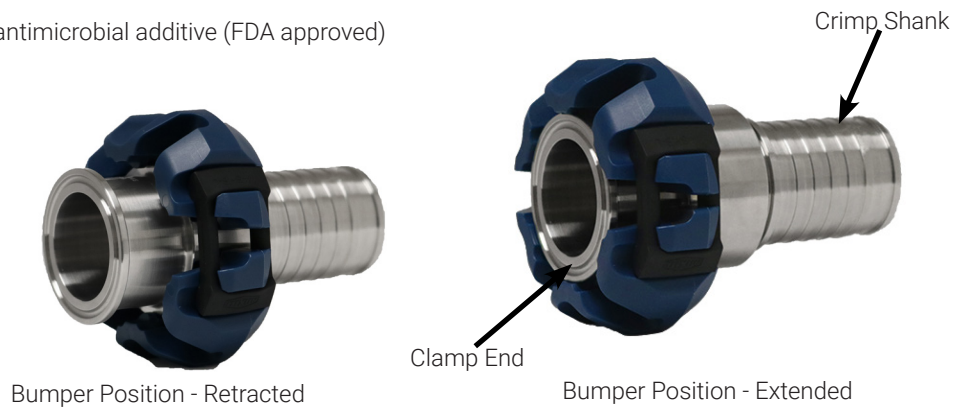

Bumper Position - Retracted

Bumper Position - Extended

## 14BA-Series Hose Bumper System

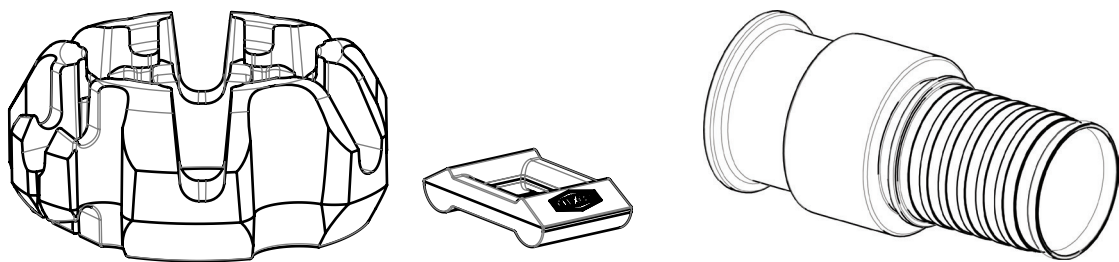

Size	Stem Material (Finish)	Stem Process Connection	Stem Shank Type	Bumper Color	Bumper Material	Bumper System Part #	Item(s) Included
1"	316L (32 Ra)	Clamp	3A 62-02 Conforming shank	Blue (standard)	Polypropylene (standard)	14BA-R10CX	(1) Hose bumper (1) Latch (1) Crimp stem
1-1/2"						14BA-R15CX	
2"						14BA-R20CX	
3"						14BA-R30CX	

NOTE: This bumper system is to be used with a crimp ferrule (not included). See chart below

Product Group: AV07

14-SHB-Series Hose Bumper - Part Number Key

14-SHB-Series Hose Bumper Part Number Key		Series	Size	Bumper Color	Bumper Material
Series	Code	14-SHB	100150		
14-SHB	14-SHB				
Size	Code				
1" - 1-1/2"	100150				
2"	200				
3"	300				
Bumper Color	Code				
Blue (standard)	blank				
Bumper Material	Code				
Polypropylene (standard)	blank				

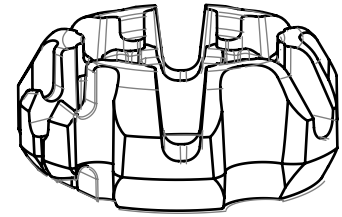

14-SHB-Series Hose Bumper System - Bill of Materials

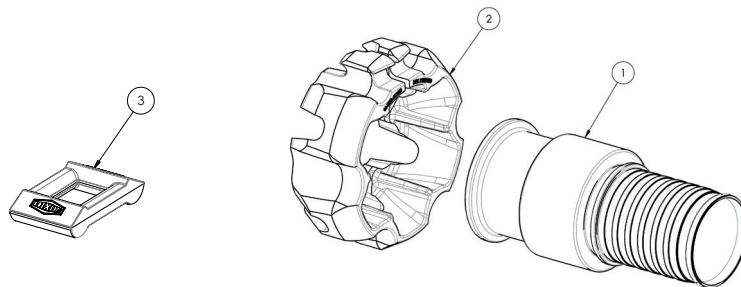

Item #	Part Number			
	1"	1-1/2"	2"	3"
1	14-SCS-R100	14-SCS-R150	14-SCSR200	14-SCS-R300
2	14-SHB-100150		14-SHB-200	14-SHB-300
3	14-SHB-L			

14-SHB-Series Hose Bumper - Dimensions

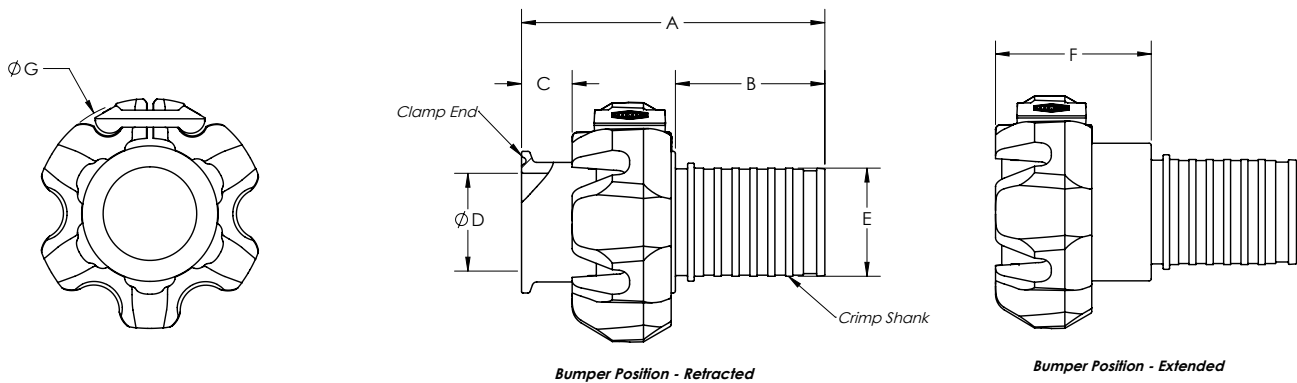

Size	Dimensions						
	A (mm)	B (mm)	C (mm)	D (mm)	E (mm)	F (mm)	G (mm)
1"	93.47	38.61	19.05	22.10	25.91	57.15	85.60
1-1/2"	107.95	53.09		34.80	25.91		
2"	120.65	66.04		47.50	51.31		
3"	131.06	76.20		72.90	76.71		



# Hygienic Fittings - Crimp Specifications

## Holedall™ Crimp Specifications

Hose Size		Stem Part Number	Description	Ferrule Part Number	Hose OD (mm)	Crimp Diameter (mm)				
mm	inch									
25.4	1	HA0224 HA0219 HA0616 HA0622 HA0640 HA0224-CIP HA0224-NZ HA0333 HA0239 HA0234	BSM Female BSM Male SMS Female SMS Male SS Sanitary Clamp BSM CIP RJT NZ Tube Weld DIN Female DIN Male	HA0249-41-3	33.0	n/a <sup>1</sup>				
					35.0	n/a <sup>1</sup>				
				HA0249-43-3	35.7	39.8				
					36.1	40.1				
				HA0249-45-3	36.5	40.4				
					36.9	40.7				
				HA0249-46-3	37.3	41.0				
					37.7	41.3				
				HA0249-47-3	38.1	41.6				
					38.5	41.9				
				HA0249-48-3	38.9	42.2				
					39.3	42.5				
				HA0249-49-3	39.7	42.8				
					40.1	43.1				
				HA0249-50-3	40.5	43.4				
					40.9	43.7				
				HA0249-51-3	41.3	44.0				
					48.4	52.4				
38.1	1½	HA0225 HA0220 HA0617 HA0623 HA0641 HA0225-CIP HA0225-NZ HA0335 HA0240 HA0235	BSM Female BSM Male SMS Female SMS Male SS Sanitary Clamp BSM CIP RJT NZ Tube Weld DIN Female DIN Male	HA0250-56-3	48.8	52.7				
					49.2	53.0				
					49.6	53.3				
					50.0	53.6				
				HA0250-58-3	50.4	53.9				
					50.8	54.2				
					51.2	54.5				
				HA025059-3	51.6	54.8				
					52.0	55.1				
					52.4	55.5				
					52.8	55.8				
				HA0250-61-3	53.2	56.1				
					53.6	56.4				
					54.0	56.7				
					54.4	57.0				
				HA0250-63-3	56.4	58.2				
					56.8	58.8				
					57.1	59.1				
					57.4	59.3				
				HA0250-64-3	57.6	59.7				
					62.7	66.3				
				50.8	2	HA0226 HA0221 HA0618 HA0624 HA0642 HA0226-CIP HA0226-NZ HA0337 HA0241 HA0236	BSM Female BSM Male SMS Female SMS Male SS Sanitary Clamp BSM CIP RJT NZ Tube Weld DIN Female DIN Male	HA0251-70-3	63.1	66.6
									63.5	66.9
									63.9	67.2
64.3	67.5									
HA0251-72-3	64.7	67.8								
	65.1	68.2								
	65.5	68.5								
HA0251-74-3	65.9	68.8								
	66.3	69.1								
	66.7	69.4								
	67.1	69.7								
HA0251-75-3	67.5	70.0								
	67.9	70.3								
	68.3	70.6								
	68.7	70.9								

<sup>1</sup>Contact Dixon™ for crimp specifications

## Hygienic Fittings - Crimp Specifications

### Holedall™ Crimp Specifications

Hose Size		Stem Part Number	Description	Ferrule Part Number	Hose OD (mm)	Crimp Diameter (mm)				
mm	inch									
63.5	2½	HA0227 HA0222 HA0229-CIP HA0619 HA0625 HA0643 HA0242 HA0237 HA0839 HA0277-NZ	BSM Female BSM Male BSM-CIP SMS Female SMS Male SS Sanitary Clamp DIN Female DIN Male Tube Weld RJT NZ	HA0252-84-3	76.1	79.6				
					76.5	79.9				
					76.9	80.2				
					77.3	80.5				
				HA0252-86-3	78.1	81.2				
					78.5	81.5				
					78.9	81.8				
					79.3	82.1				
					81.1	83.3				
					81.5	83.8				
				HA0252-89-3	81.9	83.9				
					82.3	84.5				
					88.0	91.4				
					88.4	91.8				
76.2	3	HA0228 HA0223 HA0620 HA0626 HA0644 HA0243 HA0238 HA0841 HA0228-NZ	BSM Female BSM Male SMS Female SMS Male SS Sanitary Clamp DIN Female DIN Male Tube Weld RJT NZ	HA0253-96-3	88.8	92.1				
					89.2	92.4				
					HA0253-98-3	90.5	93.6			
						90.9	93.9			
				91.3		94.2				
				91.7		94.5				
				HA0253-100-3	92.1	94.8				
					92.5	95.1				
					92.9	95.4				
					93.3	95.7				
				HA0253-101-3	93.7	96.0				
					94.1	96.3				
					94.5	96.6				
					94.8	96.9				
				HA0253-103-3	95.3	97.2				
					95.7	97.5				
					96.0	97.8				
					96.4	98.2				
				HA0253-105-3	96.9	98.5				
					97.2	98.8				
					97.6	99.1				
					98.0	99.4				
				HA0253-106-3	98.4	99.7				
					98.8	100.0				
					99.2	100.3				
					99.6	100.6				
				101.6	4	HA0294 HA0293 HA0621 HA0627 HA0645 HA0244 HA0239 HA0843 HA0294-NA	BSM Female BSM Male SMS Female SMS Male SS Sanitary Clamp DIN Female DIN Male Tube Weld RJT NZ	HA0301-129-5	117.5	123.4
									117.9	123.7
118.3	124.0									
118.9	124.3									
HA0301-130-5	119.1	124.6								
	119.5	124.9								
	119.9	125.2								
	120.2	125.5								
HA0301-132-5	120.7	125.8								
	121.1	126.1								
	121.4	126.4								
	121.8	126.8								
HA0301-133-5	122.3	127.1								
	122.6	127.4								
	123.0	127.7								
	123.4	128.0								
HA0301-135-5	123.8	128.3								
	124.2	128.6								
	124.6	128.9								
	125.0	129.2								
HA0301-136-5	128.9	n/a <sup>1</sup>								
	130.18	n/a <sup>1</sup>								

M

## Clamp Ferrules

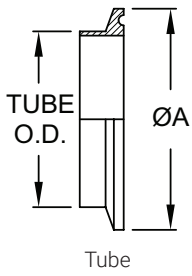

Tube OD		ØA (mm)
mm	inches	
12.7	½	25.1
19.05	¾	25.1
25.4	1	50.5
38.1	1½	50.5
50.8	2	64.0
63.5	2½	77.5
76.2	3	91.0
101.6	4	119.0
127	5	166.1
152.4	6	212.5
203.2	8	218.5
254	10	268.4
304.8	12	319.2

## Pipe

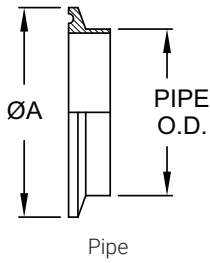

Pipe OD		ØA (mm)
mm	inches	
25.4	1	1.984
31.75	1¼	2.516
38.1	1½	2.516
50.8	2	3.047
63.5	2½	3.579
76.2	3	4.125
101.6	4	5.125
152.4	6	7.195
203.2	8	9.200

## Clamp Connections

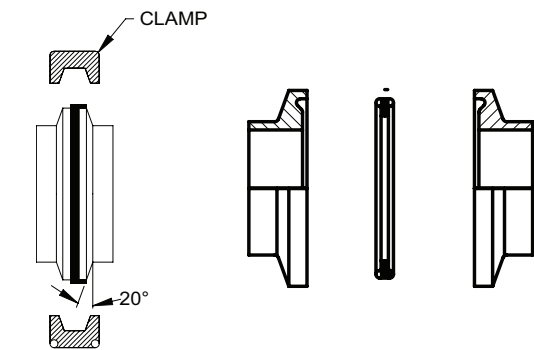

Sizes 1" to 12"

Sizes ½" & ¾"

## Gaskets

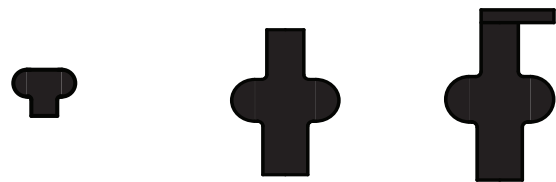

Type 1 - Standard  
½" & ¾"

Type 1 - Standard  
1" to 12"

Type 2 - Flanged  
1" to 12"

## RJT Liners & Males

### Liner

Tube OD		ØA (mm)
mm	inches	
25.4	1	41.3
38.1	1½	54.0
50.8	2	66.7
63.5	2½	79.4
76.2	3	92.1
101.6	4	117.5

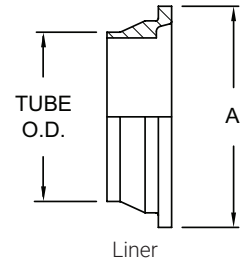

### Male

Tube OD		ØA (mm)
mm	inches	
25.4	1	33.3
38.1	1½	46.0
50.8	2	58.7
63.5	2½	71.4
76.2	3	84.1
101.6	4	109.5

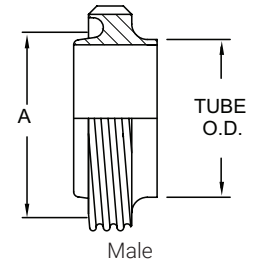

### RJT Hex Nuts

Tube OD (inches)	A Thread ID (mm)	B Across Flats (mm)	Threads Per Inch
1	33.3	50.8	8
1½	46.0	65.0	8
2	58.7	79.4	6
2½	71.4	92.1	6
3	84.1	104.8	6
4	109.5	130.2	6

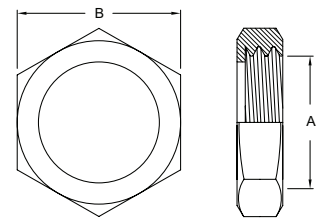

### RJT Thread Form

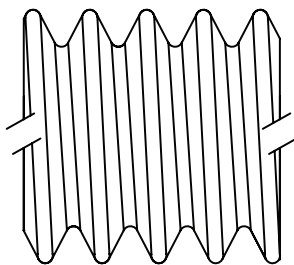

Male Thread

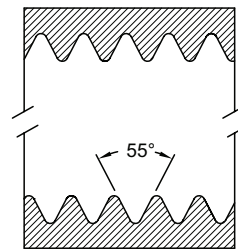

Female Thread

### Gaskets

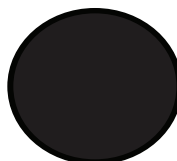

Also known as BSM (British Standard Milk) in Australia modified into Australian CIP Union

# Hygienic Fittings - Fittings Identification

## DIN 11851 Liners & Males

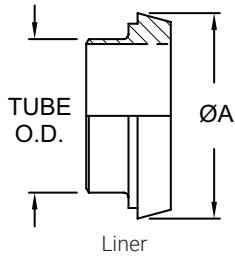

Tube OD		ØA (mm)
mm	inches	
25.4	1	43.90
38.1	1½	55.88
50.8	2	68.07
63.5	2½	86.12
76.2	3	100.08
101.6	4	120.90

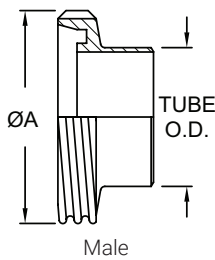

Tube OD		ØA (mm)
mm	inches	
25.4	1	51.82
38.1	1½	65.02
50.8	2	77.98
63.5	2½	95.00
76.2	3	109.47
101.6	4	129.54

### DIN Round Nuts

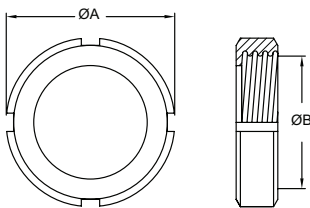

Tube OD (inches)	DN	ØA (mm)	B Thread ID (mm)	Threads Per Inch
1	25.4	63.00	47.75	6
1½	38.1	77.98	60.71	6
2	50.8	91.95	73.66	6
2½	63.5	112.01	88.65	6
3	76.2	127.00	105.16	4
4	101.6	148.08	125.48	4

### DIN Thread Form

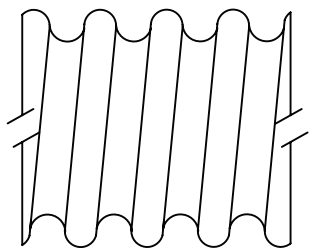

Male Thread

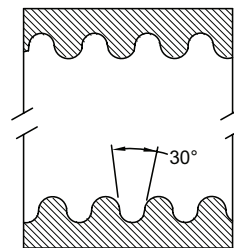

Female Thread

### Gaskets



Type A

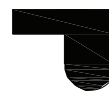

Type B

## Australian CIP Flat Face Liners & Males

### Liner

Tube OD		ØA (mm)
mm	inches	
25.4	1	41.3
38.1	1½	54.0
50.8	2	66.7
63.5	2½	79.4
76.2	3	92.1
101.6	4	117.5

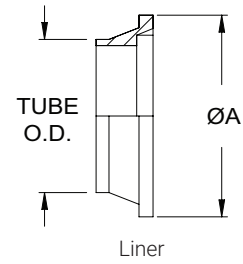

### Male

Tube OD		ØA (mm)
mm	inches	
25.4	1	33.3
38.1	1½	46.0
50.8	2	58.7
63.5	2½	71.4
76.2	3	84.1
101.6	4	109.5

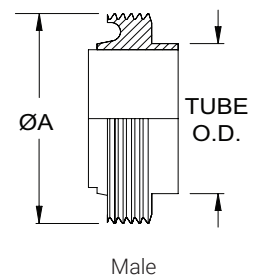

### Hex Nuts

Tube OD (inches)	DN	A (mm)	B Thread ID (mm)	Threads Per Inch
1	25.4	50.8	33.3	6
1½	38.1	65.0	46.0	6
2	50.8	79.4	58.7	6
2½	63.5	92.1	71.4	6
3	76.2	104.8	84.1	4
4	101.6	130.2	109.5	4

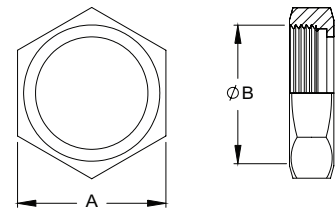

### RJT Thread Form

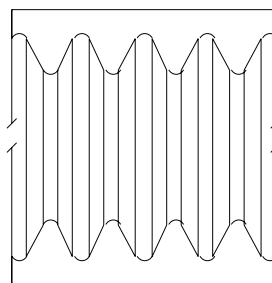

Male Thread

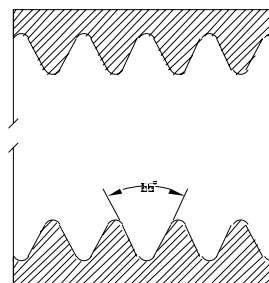

Female Thread

### Gaskets

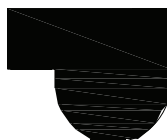

Also known as BSM (British Standard Milk) in Australia modified into Australian CIP Union

# Hygienic Fittings - Fittings Identification

## New Zealand RJT Liners & Males

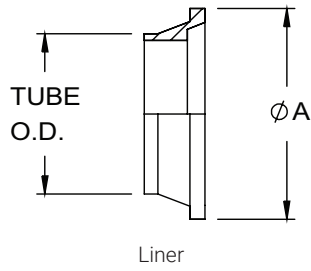

### Liner

Tube OD		ØA (mm)
mm	inches	
25.4	1	91.3
38.1	1½	54.0
50.8	2	66.7
63.5	2½	79.4
76.2	3	92.1
101.6	4	117.5

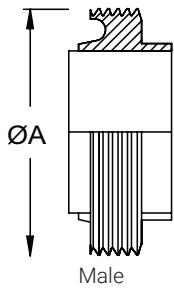

### Male

Tube OD		ØA (mm)
mm	inches	
25.4	1	33.3
38.1	1½	46.0
50.8	2	58.7
63.5	2½	71.4
76.2	3	84.1
101.6	4	109.5

### Hex Nuts

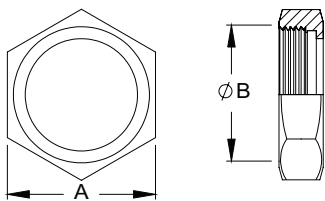

Tube OD (inches)	DN	A (mm)	ØB Thread ID (mm)	Threads Per Inch
1	25	63.00	47.75	6
1½	40	77.98	60.71	6
2	50	91.95	73.66	6
2½	65	112.01	88.65	6
3	80	127.00	105.16	4
4	100	148.08	125.48	4

### Round Nuts

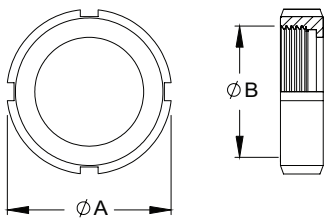

Tube OD (inches)	DN	ØA (mm)	ØB Thread ID (mm)	Threads Per Inch
1	25	63.00	47.75	6
1½	40	77.98	60.71	6
2	50	91.95	73.66	6
2½	65	112.01	88.65	6
3	80	127.00	105.16	4
4	100	148.08	125.48	4

### RJT Thread Form

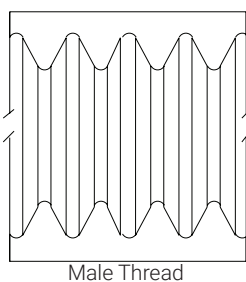

Male Thread

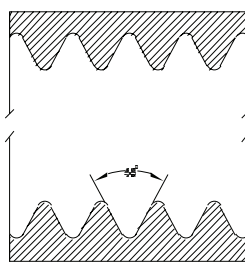

Female Thread

### Gaskets





## SMS Liners & Males

### Liner

Tube OD		ØA (mm)
mm	inches	
25.4	1	35.56
38.1	1½	55.11
50.8	2	65.00
63.5	2½	80.01
76.2	3	92.96
101.6	4	118.11

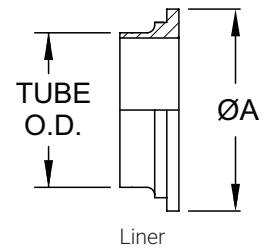

### Male

Tube OD		ØA (mm)
mm	inches	
25.4	1	39.37
38.1	1½	59.44
50.8	2	69.60
63.5	2½	84.58
76.2	3	97.54
101.6	4	124.46

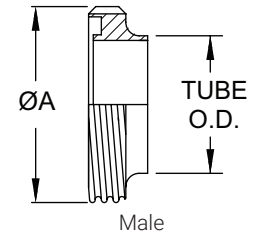

### Round Nuts

Tube OD (inches)	ØA Thread ID (mm)	ØB (mm)	Threads Per Inch
1	36.58	51.05	6
1½	56.39	73.90	6
2	66.55	84.07	6
2½	81.53	100.08	6
3	94.49	114.05	6
4	119.89	137.92	4

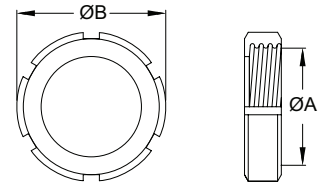

### SMS Thread Form

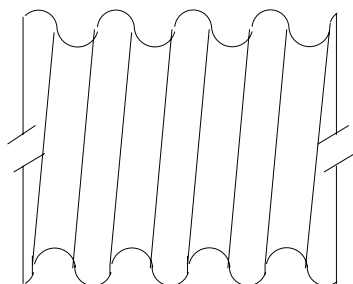

Male Thread

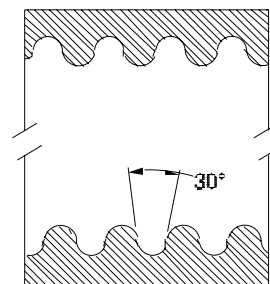

Female Thread

### Gaskets



L Gasket



R Gasket

M

