

# MAINTENANCE & OPERATING INSTRUCTIONS

*For*  
**DIXON**

## 5500 SERIES API RACK COUPLER

### For Sales & Service Contact

**USA:**

**Dixon Bayco USA**  
Chestertown, Maryland  
Phone: 410-778-2000  
Fax: 410-778-4702  
Toll Free: 800-355-1991  
E-mail: [dixonbayco@dixonvalve.com](mailto:dixonbayco@dixonvalve.com)

**Canada:**

Dixon Group Canada Limited  
Mississauga, Ontario  
Phone: 905-673-5999  
Fax: 905-673-2454  
Toll Free: 877-963-4966  
E-mail: [isales@dixongroupcanada.com](mailto:isales@dixongroupcanada.com)

**Mexico:**

**Dixva, S. de R.L. de C.V.**  
Monterrey, N.L.  
Phone: 01-800-00-DIXON (34966)  
Fax: 01-81-8354-8197  
E-mail: [contactenos@dixonvalve.com.mx](mailto:contactenos@dixonvalve.com.mx)

**Europe:**

**Dixon Group Europe Ltd**  
Preston, England  
Phone: +44 (0)1772 323529  
Fax: +44 (0)1772 314664  
E-mail: [enquiries@dixoneurope.co.uk](mailto:enquiries@dixoneurope.co.uk)

**Asia Pacific:**

**Dixon (Asia Pacific) Pty Ltd**  
Wingfield, South Australia  
Phone: +61 8 8202 6000  
Fax: +61 8 8202 6099  
E-mail: [enquiries@dixonvalve.com.au](mailto:enquiries@dixonvalve.com.au)



*The Right Connection®*

[dixonvalve.com](http://dixonvalve.com)

# 5500 Series API Rack Coupler Model Numbers

5500G.....	FKM GFLT SEALS, ALUMINUM HANDLE
5500B.....	FKM B SEALS, ALUMINUM HANDLE
5500E.....	EPDM SEALS, ALUMINUM HANDLE
5500F.....	FLUROSILICONE SEALS, ALUMINUM HANDLE
5500BL.....	BAYLAST SEALS, ALUMINUM HANDLE
5500K.....	FFKM SEALS, ALUMINUM HANDLE
5500H.....	HIFLUOR SEALS, ALUMINUM HANDLE
5500G-L.....	FKM GFLT SEALS, ALUMINUM LOCKING HANDLE
5500B-L.....	FKM B SEALS, ALUMINUM LOCKING HANDLE
5500E-L.....	EPDM SEALS, ALUMINUM LOCKING HANDLE
5500F-L.....	FLUROSILICONE SEALS, ALUMINUM LOCKING HANDLE
5500BL-L.....	BAYLAST SEALS, ALUMINUM LOCKING HANDLE
5500K-L.....	FFKM SEALS, ALUMINUM LOCKING HANDLE
5500H-L.....	HIFLUOR SEALS, ALUMINUM LOCKING HANDLE
5500G-SS.....	FKM GFLT SEALS, STAINLESS STEEL HANDLE
5500B-SS.....	FKM B SEALS, STAINLESS STEEL HANDLE
5500E-SS.....	EPDM SEALS, STAINLESS STEEL HANDLE
5500F-SS.....	FLUROSILICONE SEALS, STAINLESS STEEL HANDLE
5500BL-SS.....	BAYLAST SEALS, STAINLESS STEEL HANDLE
5500K-SS.....	FFKM SEALS, STAINLESS STEEL HANDLE
5500H-SS.....	HIFLUOR SEALS, STAINLESS STEEL HANDLE
5500G-SSL.....	FKM GFLT SEALS, STAINLESS STEEL LOCKING HANDLE
5500B-SSL.....	FKM B SEALS, STAINLESS STEEL LOCKING HANDLE
5500E-SSL.....	EPDM SEALS, STAINLESS STEEL LOCKING HANDLE
5500F-SSL.....	FLUROSILICONE SEALS, STAINLESS STEEL LOCKING HANDLE
5500BL-SSL.....	BAYLAST SEALS, STAINLESS STEEL LOCKING HANDLE
5500K-SSL.....	FFKM SEALS, STAINLESS STEEL LOCKING HANDLE
5500H-SSL.....	HIFLUOR SEALS, STAINLESS STEEL LOCKING HANDLE
5500G-SH.....	FKM GFLT SEALS, SHORT ALUMINUM HANDLE
5500B-SH.....	FKM B SEALS, SHORT ALUMINUM HANDLE
5500E-SH.....	EPDM SEALS, SHORT ALUMINUM HANDLE
5500F-SH.....	FLUROSILICONE SEALS, SHORT ALUMINUM HANDLE
5500BL-SH.....	BAYLAST SEALS, SHORT ALUMINUM HANDLE
5500K-SH.....	FFKM SEALS, SHORT ALUMINUM HANDLE
5500H-SH.....	HIFLUOR SEALS, SHORT ALUMINUM HANDLE



# API RACK COUPLER – 5500 SERIES

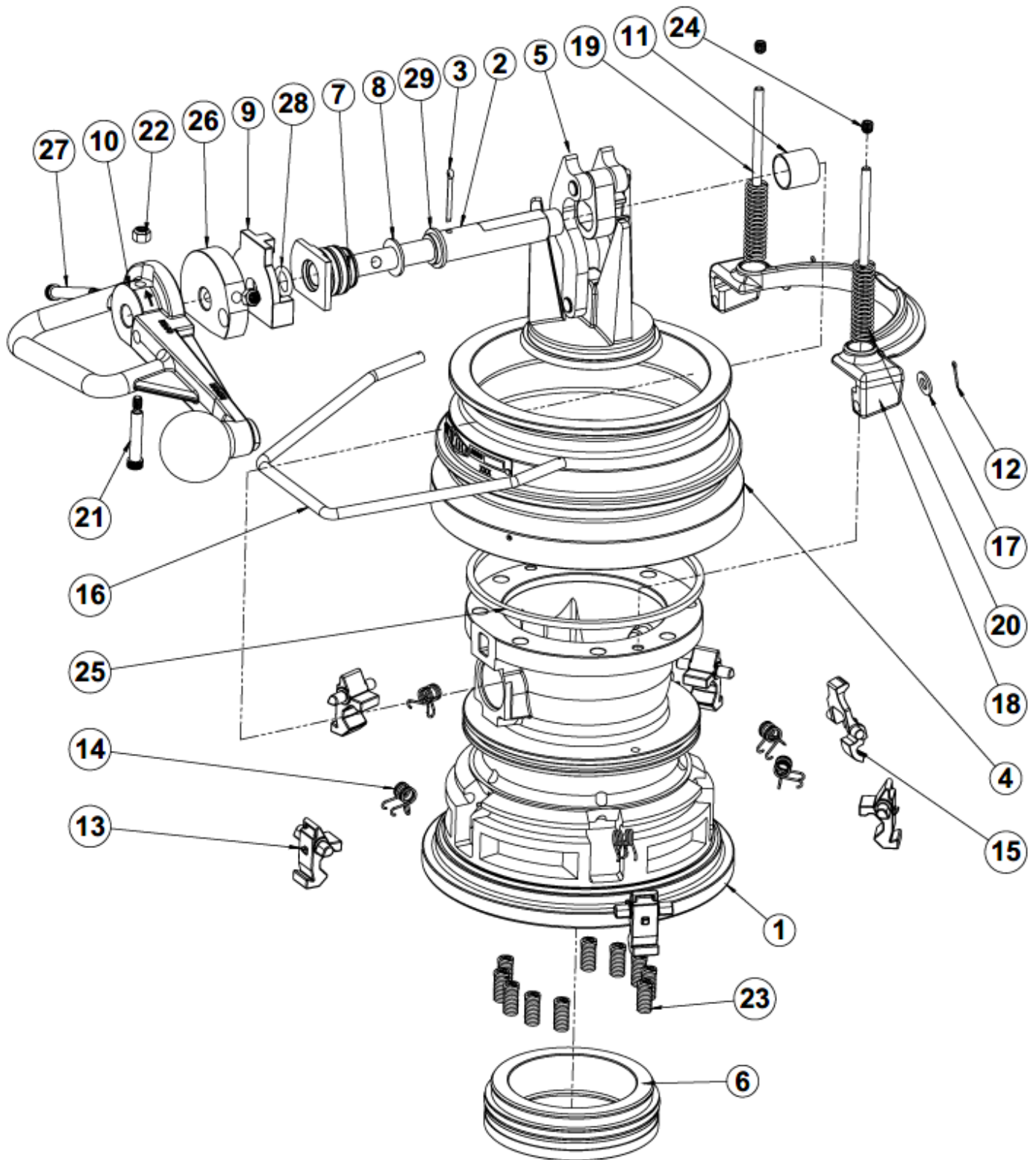

## 5500 Series API Rack coupler Sub-assembly Components

Item #	Description	Part #	Q'ty
4	Sleeve Assembly	400764	-
4.1	Sleeve	-	1
4.2	Sleeve Insert	-	1
4.3	Sleeve Pin	-	3
4.4	Grip Nail	-	2
4.5	Tag	-	1
5	Valve Assembly	400739	-
5.1	Poppet	341934	1
5.2	Bend Link	112151	2
5.3	Bend Link Pin	391141	2
5.4	Washer	112602	2
5.5	Cotter Pin	110721	2
5.6	Drive Link	112148	1
6	Nose Seal Assy	See Dixon website for kit numbers	-
6.1	Nose Piece	391877	1
6.2	O-Ring 349	See Dixon website for kit numbers	1
6.3	Nose Seal	See Dixon website for kit numbers	1
6.4	Dust Felt Ring	112174	1
6.5*	U-Seal 349	See Dixon website for kit numbers	1
7	Bearing Assembly	See Dixon website for kit numbers	-
7.1	Bearing	341936	1
7.2	O-Ring 208	See Dixon website for kit numbers	1
7.3	O-Ring 216	See Dixon website for kit numbers	2
7.4*	U-Seal 208	See Dixon website for kit numbers	1
7.5*	U-Seal 216	See Dixon website for kit numbers	1

\*Items are optional PTFE U seals. When the U seals are added to the coupler, they isolate the main rubber seals from the liquid being conveyed, thereby increasing the longevity of the rubber seals. Contact Dixon for kit numbers.

**NOTE:**  
**SLEEVE ASSEMBLY SHOULD BE REPLACED AS A WHOLE.**  
**SLEEVE ASSEMBLY SHOULD NOT BE DISASSEMBLED.**

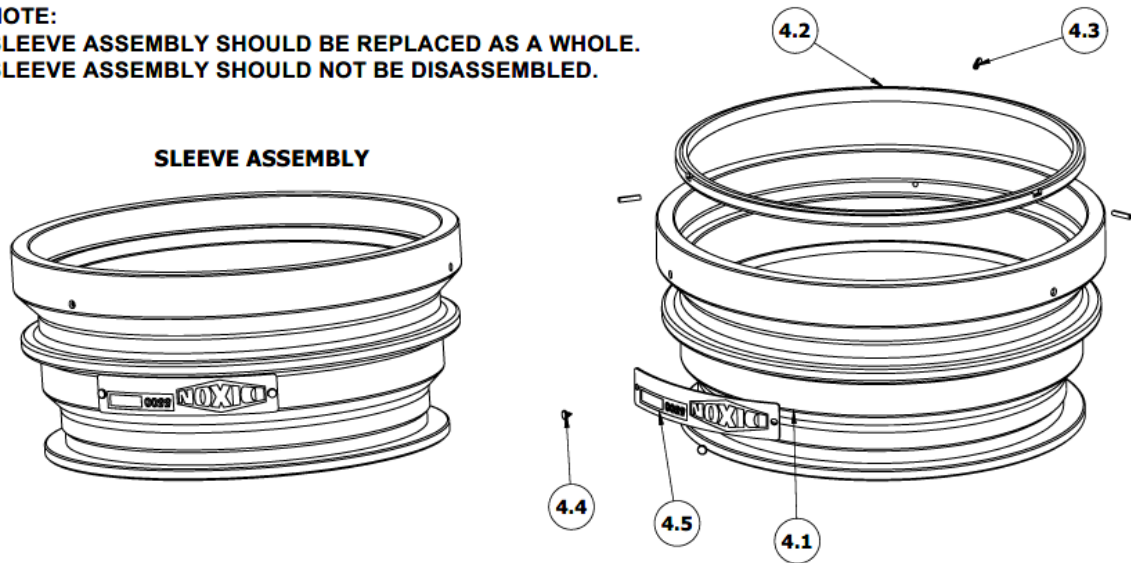

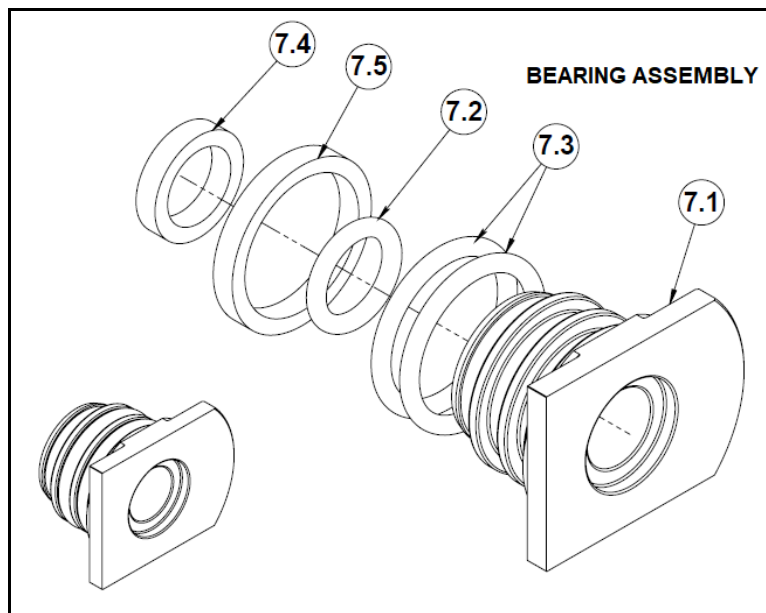
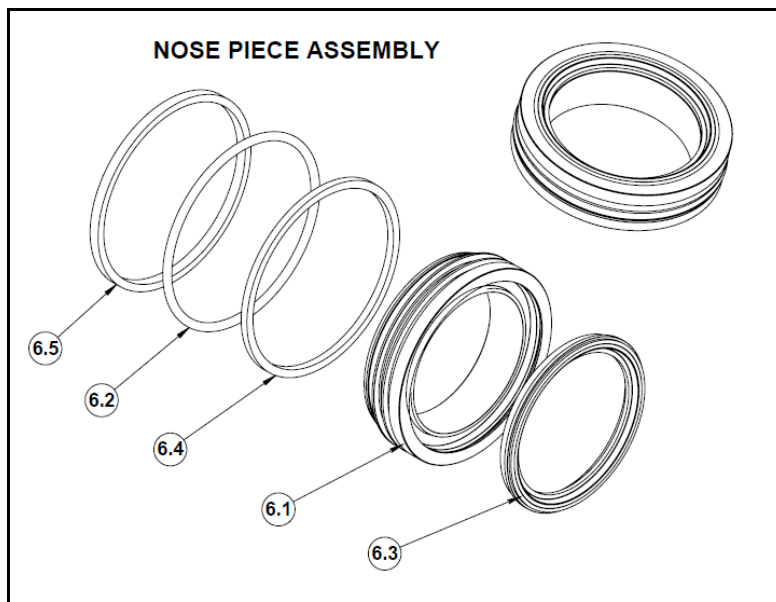
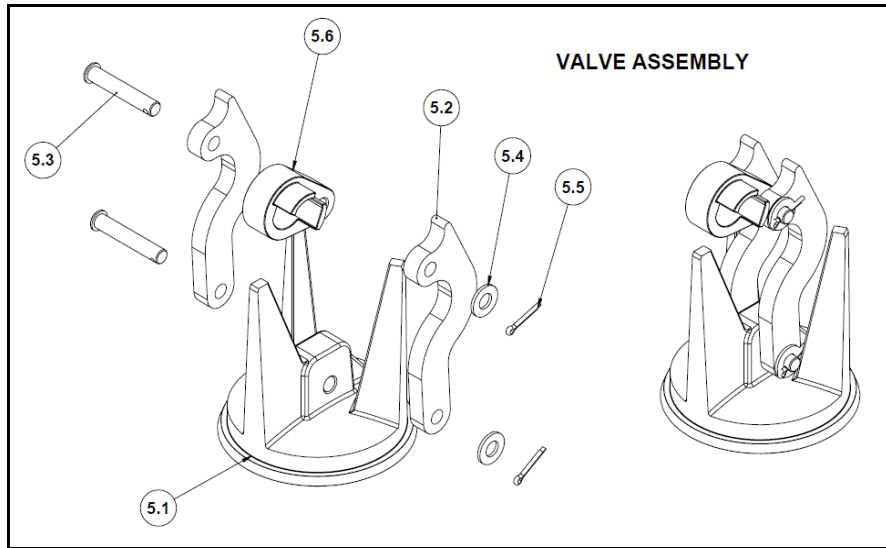

These instructions and recommendations are provided to ensure proper operation and long service life of the Dixon 5500 API rack coupler. Parts are identified by the item numbers on the assembly drawing and part list.

## **SUGGESTED MAINTENANCE SCHEDULE:**

### **1. MONTHLY INSPECTION**

Visual inspection of the API rack coupler operation can be done while the API rack coupler is still on the loading arm. All safety precautions that apply to the use of the API rack coupler must be followed.

While the API rack coupler is still on the loading arm, visually examine the API rack coupler for any worn or damaged parts, such as the body (1), sleeve (4), handle (10), bail (18), poppet (5.1), nose seal (6.3), interlocking cams (13), latch (15), flange bolts, etc, or any other condition that may affect the operation of the API rack coupler.

Examine the API rack coupler to make sure that the API rack coupler functions well. See Clause 3 in Section **“INSTALL API RACK COUPLER TO LOADING ARM”** for procedures.

Check the handle (10) for free and easy movement of the opening and closing cycle. Operation of the handle (10) normally requires limited effort. If operating the handle (10) involves stronger force, it implies the need to clean and possibly replace the shaft bearing (7) and the shaft (2).

During service time when the line is filled with liquid product, visually check for evidence of leakage, especially through the shaft seals (7.2, 7.3, 7.4, 7.5 and 28), nose piece seals (6.2, 6.5), nose seal (6.3) and the flange gasket. Any evidence of leakage means there is a need for further maintenance.

### **2. YEARLY INSPECTION**

For yearly inspection, the API rack coupler should be removed from the loading arm. See Section **“DISMANTLE API RACK COUPLER FROM LOADING ARM”** for procedures of how to dismantle the API rack coupler from the loading arm. See Section **“DISASSEMBLY”** for procedures of how to disassemble the API rack coupler for further maintenance.

It is recommended that all seals (6.2, 6.3, 6.5, 7.2, 7.3, 7.4,7.5 and 28) should be inspected every 12 months. Replace any worn or damaged seals. See Section **“REPLACE SEALS”** for procedures.

It is recommended that the valve assembly should be inspected every 12 months. Check the bent links (5.2), and poppet (5.1) carefully to make sure that there is no permanent deformation, wear, cracking, or any other damage. Check the bent link pins (5.3) carefully to make sure there is no permanent deformation such as bending and cracking. Replace any deformed, worn or damaged parts in the valve assembly. See Section **“REPLACE VALVE ASSEMBLY AND PARTS”** for procedures.

**Warning:** Deformed bent link pins (5.3), drive link (5.6) and bent links (5.2) may cause leakage through poppet seals. Further service will lead to cracks and breakage, which will cause a complete failure of the API rack coupler.

Visually examine the shaft (2) every 12 months for significant dirt accumulation that could cause shaft seal leakage. Visually examine the shaft (2), bearing washer (8), handle (10) and shoulder screw (21) for wear and damage. Replace any worn or damaged parts.

**Warning:** If the shoulder screws (21 and 27) break, this can cause the poppet to be left in partially open position which may cause spill. Replace the shoulder screws (21 and 27) when they show sign of wear or damage.

Visually examine the nose piece assembly every 12 months for significant dirt accumulation that could cause nose piece seal leakage.

Visually examine the body (1), sleeve (4), interlocking cams (13), latch (15) and torsion springs (14) for wear or damage every 12 months. Check the interlocking cam groove on the sleeve (4) for wear and damage. Replace any worn or damaged parts.

**Warning:** If there is significant wear on the interlocking cam groove of the sleeve (4) or the interlocking cams (13), replace the sleeve (4) or interlocking cams (13) immediately. Failure to replace these parts can cause failure to interlock the API rack coupler.

### 3. SEAL REPLACEMENT

It is recommended that seals should be replaced with appropriate API rack coupler seal kit every 2 years, or at the first evidence of leakage. See Section “**REPLACE SEALS**” for procedures.

### 4. OVERHAUL

It is recommended that a complete overhaul of the API rack coupler should be performed every 4 years, or at the first evidence of leakage. Complete overhaul would involve seal inspection and replacement, valve assembly inspection, inspection of body (1), sleeve (4), shaft (2), interlocking cams (13), latch (15) and springs (14, 20). Replace any worn or damaged parts immediately. See corresponding sections for procedures.

**CAUTION! WHEN THE API RACK COUPLER POPPET (5.1) IS UNDER PRESSURE, THE HANDLE (10) OF THE API RACK COUPLER MAY ROTATE VIOLENTLY. PERSONAL INJURIES MAY RESULT IF THIS PRECAUTION IS NOT TAKEN.**

## INSTALL API RACK COUPLER TO LOADING ARM:

**Warning:** Read and understand this instruction manual before starting installation.

1. Check the API rack coupler to make sure that there is no damage.
2. Secure the loading arm. Align the TTMA 4” flange of the API rack coupler to the loading arm end flange with TTMA 4” gasket. Insert two bolts into the top bolt holes on the flanges and hand tighten the bolts first. Install the remaining six bolts and tighten all the bolts.
3. Make sure that all other devices for the loading arm are properly installed and ready for use. Make sure that there is no liquid product in the line. Snap the API rack coupler onto an API adapter. Check the followings:
  - Make sure that the nose ring of API adapter is locked by the five interlocking cams (13) of the API rack coupler.
  - Make sure that the sleeve (4) moves fully forward to the outlet of the API rack coupler.
  - If the sleeve (4) is in place, check the interlock by pulling back the API rack coupler or bending the API rack coupler sideways without triggering the release (16). The API rack coupler should be locked tightly.
  - If the API rack coupler is locked tightly, fully rotate the handle (10) to the open position. Make sure that the handle (10) can rotate freely and the poppet (5.1) of the API rack coupler can push the poppet of the API adapter to the open position.



- When the poppet (5.1) of the API rack coupler is in the open position, try to trigger the release (16) to make sure that the sleeve (4) is locked by the interlocking cam surface of the handle (10).
- Rotate the handle (10) to fully closed position. Trigger the release (16). The sleeve (4) should move back and five interlocking cams (13) should unlock the nose ring of the API adapter. The API rack coupler should be able to be removed from the API adapter.
- If there are problems with any of the above, see the following section to dismantle the API rack coupler from the API adapter and remove the API rack coupler from the loading arm. See Section “**DISASSEMBLY**” for further instructions of how to disassemble the API rack coupler to inspect individual parts. Contact the factory if it is a new API rack coupler.

## **DISMANTLE API RACK COUPLER FROM LOADING ARM:**

**Warning:** Read and understand this instruction manual before starting installation. Make sure that there is adequate personal protection all the time when dismantling the API rack coupler from the loading arm.

1. Shut off all working devices. Drain the loading arm. Dismantle the API rack coupler when it is clean and dry.
2. Secure the loading arm from movement and support the API rack coupler. Make sure that the API rack coupler is fully closed.
3. Loosen the bolts on the TTMA flange of the API rack coupler. Leave the two top bolts on and remove the remaining six bolts first. And then remove the two top bolts.
4. Remove the API rack coupler from the loading arm. Remove the TTMA gasket between the flanges.

## **REPLACE VALVE ASSEMBLY AND PARTS:**

**Note:** Valve assembly (5) and parts can only be replaced when the API rack coupler is off the rack. The design of the Dixon API rack coupler shaft (2) makes it easy to remove the valve assembly from the API rack coupler as a whole. This makes it easy to replace the whole valve assembly (5) or any individual part of the valve assembly (5). There is **NO** need to remove the bent link pins (5.3) from the bent links (5.2) while the valve assembly is still in the API rack coupler.

**Warning:** Carefully handle the poppet (5.1) without damaging the sealing surface when replacing valve assembly or parts. Even the smallest scratches on the sealing surface can cause leakage.

1. When the API rack coupler is off the rack, **DO NOT** remove the handle shoulder screw (21) and lock nut (22) from the handle (10) yet same as the shoulder screw (27) and lock nut of sleeve lock (26). When API rack coupler is closed, remove the shaft cotter pin (3) from the shaft (2) by using pliers.
2. Defeat the interlock manually or use an API adapter nose ring so the sleeve (4) can move fully forward to the outlet of the API rack coupler.
3. Turn the handle (10) to open the API rack coupler.
4. Pull out the shaft and handle assembly with locking plate (9), dust O-ring (28), bearing assembly (7), bearing washer (8), while inside shaft washer (29), valve assembly (5) and spacer (11) will fall free of the shaft (2).
5. Inspect all parts of the valve assembly (5) and replace any damaged parts. When reassembling the valve assembly, make sure the bent links (5.2) and the drive link (5.6) are assembled in the same orientation as shown in the valve assembly figure.
6. Assemble the shaft and handle assembly with sleeve lock (26), locking plate (9), dust O-ring (28), bearing assembly (7) and bearing washer (8) to the body (1). Assemble the inside shaft washer (29), drive link (5.6) and the spacer (11) before pushing the other end of the

shaft (2) into the shaft end pocket on the body (1). Pay attention to the orientation of the valve assembly.

7. Rotate the handle (10) to fully closed position. Install the shaft cotter pin (3) onto the shaft (2).
8. Check the API rack coupler with an API adapter to make sure all components are assembled properly.

## REPLACE SEALS:

**Warning:** Carefully remove and install parts without damaging any sealing surfaces when replacing seals. Even the smallest scratches on the O-Ring groove or other sealing surface will cause leakage.

### REPLACE SHAFT SEALS IN STUFFING BOX

**Note:** While the API rack coupler is off the rack, shaft seals (7.2, 7.3, 7.4, 7.5 and 28) can be replaced using the method described here.

1. Follow Step 1 to 4 from “**REPLACE VALVE ASSEMBLY AND PARTS**”.
2. To remove bearing assembly (7), unscrew the lock nuts (22) and remove the shoulder screw (21) from the handle (10) and shoulder screw (27) from the sleeve lock (26). Remove the handle (10) from the shaft (2) followed by the sleeve lock (26), locking plate (9), dust O-ring (28), the bearing assembly (7) and bearing washer (8).
3. Remove the O-rings (7.2, 7.3) and the u-seals (7.4, 7.5, optional) from the bearing assembly and make sure not to damage the bearing (7.1) or scratch sealing surfaces.
  - If the bearing (7.1) is good, thoroughly clean the bearing (7.1) to remove any debris, oil and grease. Lubricate NEW O-Rings (7.2 for inside groove and 7.3 for outside groove) and install into the grooves. If u-seals (7.4, 7.5) are ordered, lubricate NEW u-seals (7.4 for inside groove and 7.5 for outside groove) and install into the grooves. Handle the u-seals (7.4, 7.5) carefully and make sure not to damage.
  - If the bearing (7.1) is already damaged or has scratches on the sealing surfaces, replace the bearing assembly with a NEW bearing assembly, which includes the bearing (7.1), the inside O-Ring (7.2), the outside O-Ring (7.3), the inside u-seal (7.4, optional) and the outside u-seal (7.5, optional).
4. Install bearing washer (8) into the shaft (2) followed by the bearing assembly (7) and dust O-ring (28) make sure it is greased, locking plate (9), sleeve lock (26) and then the handle (10). Align the sleeve lock (26) and handle (10) to the shaft (2) holes and insert the shoulder screws (21 & 27) then tighten the lock nuts (22).
5. Push the end of the shaft to the body through the inside shaft washer (29), drive link (5.6) and spacer (11). At this instance the bearing assembly is also getting in to the stuffing box of the body. Push the shaft assemble shaft (2) end to the shaft pocket on the body (1). Pay attention to the orientation of the valve assembly.
6. Rotate the handle (10) to fully closed position. Install the shaft cotter pin (3) onto the shaft (2).
7. Check the API rack coupler with an API adapter to make sure all components are assembled properly.

### REPLACE THE SEALS ON THE NOSE PIECE

**Note:** Nose piece seals, including O-Ring (6.2), nose piece dust ring (6.4) and optional u-seal (6.5), can only be replaced when the API rack coupler is off the rack.

1. Follow Step 1 to 4 from “**REPLACE VALVE ASSEMBLY AND PARTS**”.
2. Remove the nose piece assembly, which includes the nose piece (6.1), nose seal (6.3), O-Ring (6.2), nose piece dust ring (6.4), u-seal (6.5, optional). Remove and clean the compression springs (23).

- Remove nose seal (6.3), O-Ring (6.2), nose piece dust ring (6.4) and u-seal (6.5, if applicable) from the nose piece (6.1).
  - Inspect the nose piece (6.1) and make sure it is not damaged. Clean seal surfaces carefully.
  - Replace nose seal (6.3), O-Ring (6.2), nose piece dust ring (6.4) and u-seal (6.5, if applicable) with new ones.
3. Assemble the compression spring (23) and nose piece assembly (6) to the body (1).
  4. Follow step 5 to 7 from “**REPLACE SHAFT SEALS IN STUFFING BOX**”.

## DISASSEMBLY:

**Warning:** Carefully remove parts without damaging any sealing surfaces when disassembling the API rack coupler. Even the smallest scratches on the O-Ring grooves or other sealing surfaces will cause leakage.

1. When the API rack coupler is closed, remove the shaft cotter pin (3) from the shaft (2) by using pliers.
2. Defeat the interlock manually or use an API adapter nose ring so the sleeve (4) can move fully forward to the outlet of the API rack coupler.
3. Turn the handle (10) to fully open position. Pull out the shaft and handle assembly with locking plate (9), dust O-ring (28), bearing assembly (7) and bearing washer (8) while the inside shaft washer (29), valve assembly (5) and spacer (11) will fall free of the shaft (2).
4. To completely disassemble the shaft and handle assembly, remove the handle lock nuts (22) and shoulder screws (21 & 27). Remove the handle (10), sleeve lock (26), locking plate (9), dust O-ring (28), bearing assembly (7) and bearing washer (8).
5. To completely disassemble the valve assembly, remove the bent link cotter pins (5.5), bent link washers (5.4), and bent link pins (5.3).
6. To completely disassemble the bearing assembly, remove O-Rings (7.2, 7.3) and u-seals (7.4, 7.5, optional) from the bearing (7.1).
7. Remove cotter pins (12) and washers (17) from the release (16) ends. Remove the release (16) from the bail (18).
8. Remove the set screws (24) from the body (1) to remove the bail pins (19).
9. Turn the API rack coupler upside down and the bail pins (19) will fall out. If the bail pins (19) do not fall out, move the bail springs (20) until the bail pins (19) fall out.
10. Remove the bail springs (20) and the bail (18).
11. Remove the sleeve (4) from the body (1) by pulling the sleeve (4) to the inlet of the body (1).
12. Remove the five interlocking cams (13) and latch (15) from the body (1). Remove the six torsion springs (14) and dust ring (25) from the body (1).
13. Remove the nose piece assembly (6) and ten compression springs (23) from the body (1).
14. To completely disassemble the nose piece assembly, remove the O-Ring (6.2), nose piece (6.1), nose piece dust ring (6.4), nose seal (6.3) and u-seal (6.5, optional) from the nose piece (6.1).

## ASSEMBLY:

**Note:** Remove any burrs and sharp edges that could damage the seals during reassembly.

1. Assemble the bearing assembly if it is disassembled. See Step 4 “**Replace shaft seals in stuffing box**” for procedures of how to assemble the bearing assembly.
2. Assemble the valve assembly if it is disassembled. See Section “**REPLACE VALVE ASSEMBLY AND PARTS**” for procedures of how to assemble the valve assembly.
3. Assemble the nose piece assembly if it is disassembled. See Section “**Replace the seals on the nose piece**” for procedures of how to assemble the nose piece assembly.

4. Assemble the shaft and handle assembly if it is disassembled. Install bearing washer (8) into the shaft (2) followed by the bearing assembly (7, make sure it is greased), dust O-ring (28), locking plate (9), sleeve lock (26) and then the handle (10). Align the handle (10) and sleeve lock (26) to the shaft (2) holes and insert the shoulder screws (21 and 27) then tighten the lock nuts (22).
5. Install the body dust ring (25) to the body dust groove.
6. Install the torsion springs (14), the latch (15) and the interlocking cams (13) to the body (1).
7. Install the compression springs (23) and the nose piece assembly to the body (1).
8. Install the sleeve (4) to the body (1). Push in the five interlocking cams (13) manually so the sleeve (4) can move fully forward to the outlet of the API rack coupler. Use nose ring of API adapter or ask others for assistance.
9. Install the shaft and handle assembly with locking plate (9), dust O-ring (28), bearing assembly (7) and bearing washer (8) to the body (1). Assemble the inside shaft washer (29), drive link (5.6) of the valve assembly and the spacer (11) before pushing the other end of the shaft (2) into the shaft pocket on the body (1). Pay attention to the orientation of the valve assembly.
10. Rotate the handle (2) to fully closed position. Install the shaft cotter pin (3) onto the shaft (2).
11. Install the bail (18), bail springs (20), bail pins (19) and tighten the set screws (24) to the body (1).
12. Install the release (16) to the bail (18). Install the washers (17) and cotter pins (12) to the ends of release (16).
13. Rotate the handle (10) to the open position and closed position several times to verify proper operation.
14. When the handle (10) is in the closed position, trigger the release (16) so the sleeve (4) can move fully backward to lock the handle (10). The API rack coupler should not be able to be opened by rotating the handle (10).
15. Check the API rack coupler with an API adapter to make sure all components are assembled properly.

**Warning:** If the sleeve subassembly (4) and interlocking cams (13) are disassembled and replaced, try coupling and uncoupling the API rack coupler to an API adapter nose ring a few times making sure the locking mechanism functions well before putting the API rack coupler back onto the loading arm.

## DIXON WARRANTY:

For Warranty Information, please refer to the inside back cover of the latest Dixon Catalogue.